

# Introduction to Hawaiian Outrigger Canoeing



**Combined Knowledge off the Web from:**

Hong Kong Paddle Club

Vernon Racing Canoe Club (Canada)

Canadian Community Dragon Boat Association

O Kalani Outrigger Canoe Club (Hawaii)

Delta Outriggers (Canada)

Ocean River Paddling Club (Canada)

Kihei Canoe Club (Hawaii)

Kent Island Outrigger Canoe Club (USA)

Gibsons Paddle Club (Canada)

Waikiki Yacht Club Canoe Team (Hawaii)

False Creek Racing Canoe Club (Canada)

Jude Turczynski (Hawaii)

Kawika Sands (Hana Hou Series)

Rich Lagrand (USA)

## A Brief History of the Sport

Vernon Racing Canoe Club

It has been said: "Canoe racing has been around as long as there have been 2 canoes."

Although outrigger canoes were standard craft in the Indian and Pacific Oceans (over half the world's surface) since time immemorial, the contemporary sport of outrigger canoe racing has its origins in the Hawaiian Islands.

Outrigger canoe racing, along with most other aspects of Polynesian culture, were lost or nearly lost in the rest of Polynesia in the 19<sup>th</sup> century but fortunately survived in Hawaii.

It is the Hawaiian outrigger canoe which is the standard canoe principally used internationally for racing.

For this reason, it is common practice to use original Hawaiian customs, traditions and names for all aspects of the sport: the techniques, the parts of the canoes, the seat assignments, etc.

Many indigenous names exist for canoe, but the more universal names used in outrigger canoe racing include: Wa'a- Hawaii, Va'a- Tahiti, Waka Ama- New Zealand.

---

## The Spirit of Aloha

Kawika Sands

In the beginning A (pronounced "ahh"), the eternal light giver, created Namaka O Ka Hai (the great power of the sea). But A saw the seas were alone, so he freed the force Pele. Pele created the lands. To keep them above her jealous sister, she constantly renewed them. The people who found these lands named it Hawai`i hailing it as a place of blessed "alo" or "aloha" meaning "in the presence of A." Life in old Hawai`i was a spiritual experience. There was aloha everywhere; in the people, plants, animals, rocks and reefs. Even in the canoes and paddles and the tools used to make them.

But aloha is more than a word, it's a way of life. If there is life, there is mana, goodness, and wisdom. If there is goodness and wisdom in a person, there is a god-quality. One must recognize the "god of life" in another before saying "Aloha." It means mutual regard and affection and extends warmth in caring with no obligation in return. It's the essence of relationships in which each person is important to every other person for collective existence. It's to hear what is not said, to see what cannot be seen and to know the unknowable.

To say "Aloha" to another with indifference is blasphemous, just as saying "Mahalo" ungraciously is profane.

Therefore, when one says "Aloha" to another, one must mean it sincerely. If you are angry with someone, you must cleanse away all ill feeling before saying "Aloha." It is said, and given, freely and without condition or expectation and with the realization that it may not be returned but it is given without regrets nonetheless. It is this concept more than any other that distinguishes the Hawaiian culture. It also allows an outrigger club and its' members to grow and thrive. A club's leaders, more than any other, should understand, and be possessed of, this concept. It is not enough to be in charge, one must lead by example.

There are many traits that express the charm, the warmth, the sincerity, the generosity, and the love of an intangible substance or spirit known to many in Hawai`i nei as "ALOHA."

Aloha is appropriate when it comes to your ho'a wa'a (canoe mates) and as your competitors. Every race is an occasion for the celebration of team spirit, meeting the challenge of competition, the test of determination, and the solidarity of club pride. So what are these traits ?

<b>Akahai</b>	Kindness. Help others where you can, let others help where possible. Remember to give credit where credit is due and do not take credit at another's expense.
<b>Lokahi</b>	Unity. Unity is to a club, what water is to a farmer. Take away a club's unity, and the club becomes a lifeless desert. By maintaining club unity you maintain a common goal and individuals are possessed with a common motive.
<b>`Olu`olu</b>	Agreeable. Commend in public, condemn in private. Remember a good judge of character corrects what he hears by what he sees, a bad judge of character corrupts what he sees by what he hears.
<b>Ha`aha`a</b>	Humility. Pride brings destruction, humility brings honor. If you are humble, you consider yourself the servant of others. You do not act or feel superior to others. Remember that a leader who excels in employing others humbles himself before them.
<b>Ahonui</b>	Patience. Never remember small faults, never forget small favors. The development of patience challenges the strongest by the minute to break away and take the easy road. It is something to admire and respect in someone, but often over looked because patience is hidden in all of us.

---

# What to Bring

---

## Be Ready to Swim

Waikiki Yacht Club Canoe Team

Boats can huli, and even the most experienced crews will sometimes find themselves in the water. Novices, of course, will be more likely to huli.

Also, during the course of a practice, coaches frequently call for crew seat changes which allow them to watch different "combinations" of paddlers and judge the performance of individuals in a boat. At those times, it's often easier to just jump out of a boat and swim to your new seat assignment, than to crawl.

Consequently:

Never carry anything in the boat you cannot afford to lose to the ocean. This includes glasses, jewelry, keys, water bottles, and clothing.

Once again:

Never carry anything in the boat you cannot afford to lose to the ocean!

---

## What to Bring

**What should I bring to practice?**

Vernon Racing Canoe Club

Answer: A lot depends on your individual preferences, however, there are some basics you should think about:

PADDLE	Of course, you need your paddle. This assumes that your commitment to the sport is such that you have purchased your own "blade."
DRINK	Paddlers should bring a small bottle of water or sports drink to carry with them in the boat.
HEAD Protection	Bring a headband, hairband or hat of some sort to keep your hair out of your face and sweat off your face.
A DRY T-SHIRT	It's up to you, but having a dry towel and a T-shirt or sweatshirt to put on after practice will be more comfortable for you. During early or late season, polypropylene is recommended as cotton is very cold.
SUNSCREEN	You really do need to protect yourself from the sun -- especially on race day at the beach and any daytime practices. Don't worry about it during weekday evening practices.
NEOPRENE	You'll see a lot of paddlers wearing neoprene (wet suit material) shorts. Neoprene is popular with paddlers because it cushions the hard seats of the canoe and minimizes chafing. Biking shorts also work well.
FOOTWEAR	All paddlers must help put boats in the water and bring them out. Early season, wetsuit booties, rubber boots are recommended.

---

## Hydration

**Water!**

Hong Kong Paddle Club

It is vital to consume fluids at during long races or during race days specially if the climate is hot and humid. You can loose up to 3% of your body fluid in less than two hours on a hot day, which can cause severe trauma to you system. For some of us that means up to 3 litres of water which needs to be replaced even during a race! This is exacerbated by the demands that carbohydrate mobilization has on you water reserves.

NEVER underestimate the need for water. Hydration should begin hours or better yet days days before a race or long training run, even if it means getting up five times in the middle of the night for relief. Urine that is thick as syrup means your blood is probably just as thick, that can result in a high heartrate and renal shut down.

**Water and the Athlete**

Canadian Community Dragon Boat Association

---

Water is a basic necessity for all life. Without it, life can't exist. Even when water is limited, living organisms suffer. You are no exception. For young athletes like yourself, not enough water means you can't do your best. It can even cause serious health problems.

Our blood circulates like an ocean within us. The water in blood helps carry nutrients and energy to our body cells. It also carries waste products away from our cells for excretion from our body. Water helps regulate our body temperature, too--an important factor for all of us.

As an athlete, you have a special need for water. When you participate in a sport like dragon boating, you burn a lot of food energy (called calories). Some of that unleashed energy powers muscles. But some of that energy is released as heat. Water keeps you from overheating. Sweating and evaporation from the skin cools you down. However, water is lost in the cooling process. That can be dangerous if the water is not replenished.

If you run low on water, your body can overheat, like a car that is low on cooling fluid. Losing just two percent of the body's water can hurt performance. A five percent loss can cause heat exhaustion. A seven percent to ten percent loss can result in heat stroke and death. Dehydration can kill.

Thirst is your body's signal that you need to drink water. By the time you feel thirsty, you may have already lost one percent to two percent of your water--and that's enough to hurt performance. But just drinking enough to satisfy your thirst may not supply your body's needs. If you drink only enough to satisfy your thirst, your body may take up to 24 hours to fully rehydrate its cells and regain maximum performance.

When you participate in a sporting event or practice session, follow these guidelines:

Don't wait until you are thirsty before drinking water.

Drink more than enough to satisfy your thirst.

Drink more than you think you need before an event or practice to make sure you are fully rehydrated.

Without enough water to cool itself, the body can overheat to dangerous levels.

The conditioned athlete is able to store and burn more energy in a shorter time. That means your body releases more heat, requires more cooling, loses more water, and needs more water to replenish its stores. Also, you may have increased your sweating response, which means you lose even more water. As an in-shape athlete, you need more water than other people.

When you feel exhausted and hot during a workout or race, drinking large amounts of water very rapidly may cause discomfort or stomach cramps. But that is not a good reason to restrict water. Drinking moderate amounts at frequent intervals is the best strategy during competition or practice. About one cup (six to eight ounces) of cool water every 15 to 20 minutes during an activity is about right for most athletes. Some athletes can drink a bit more than this at each interval. Cool water (40 to 50 degrees Fahrenheit) is best. Cool water helps absorb body heat. And it empties from the stomach into the intestine at a fast rate, which allows it to be absorbed rapidly into the body.

Some drinks that have caffeine, such as colas and iced tea, are advertised as thirst quenchers. Do not use caffeine-containing beverages as fluid rehydration drinks shortly before, during, and after a practice or competition. Caffeine acts as a diuretic. It increases urine output and can promote dehydration.

Your biggest concern is getting enough water--pure, cool water. Even the salt you lose while sweating can be easily replaced by adding salt to foods.

Plain, cool water is the fluid of choice when the actual exercise does not last longer than 60 to 90 minutes. And that includes most situations, even a tough practice session. You don't need an energy source in the fluid you drink to rehydrate. During these normal situations, if you have been eating and training properly, you should have enough energy stored as liver and muscle glycogen to power you through.

There are many different commercial sport drinks available. They contain varying kinds and amounts of carbohydrates and electrolytes. For example, GATORADE is a glucose electrolyte solution of about six percent carbohydrate concentration. Exceed is a glucose polymer solution of about seven percent carbohydrate concentration. If you use a sport drink, pick one that has less than eight percent total solids (carbohydrates, electrolytes). More concentrated solutions can delay fluid absorption. They must be diluted with plain water before you use them as a fluid replacement drink. Also, avoid sport drinks that contain fructose as the only source of carbohydrate. Fructose may delay gastric emptying of fluid and cause upset stomach. And fructose must first be converted to glucose before it can be used for energy. This conversion means you can't use fructose as an energy source as quickly as other carbohydrates.

Fruit juices like orange juice should also be diluted if you're using them as a fluid replacement drink before, during, or after an event or practice session. Fruit juices vary from 10% to 17% carbohydrate concentration. Dilute them with an equal amount of pure water before you use them as fluid replacement. Of course, when you drink juices at other times, such as with a meal or snack, you don't have to dilute them.

---

Take every opportunity to drink water and other appropriate fluids. Drink fluids every day, even when you are not thirsty. That means drinking at mealtime--and snacktime, too! As a competition or practice approaches, follow these guidelines:

Drink plenty of appropriate fluids the 24 hours before an event. Give your body every opportunity to become fully rehydrated.

If you eat a pregame meal three or more hours before an event, make sure that ample fluids are included--at least two cups (16 ounces).

About 15 to 30 minutes before the start of competition or practice, drink a cup or more of fluids. This will help ensure that your tissues are fully rehydrated at the start.

**During the activity, drink six to eight ounces of fluids every 15 to 20 minutes.** Drinking moderate amounts frequently is the best way to keep fluid levels up. If you drink too much too quickly, you may develop stomach cramps and other discomfort.

**Drink plenty of fluids after the activity.** If you weigh in before and after activities, drink two cups (16 ounces) for every pound lost until you are within a pound of your pre-activity weight.

**Remember to drink fluids before you get thirsty.** If you wait until you're thirsty, your body may have already lost enough water to hurt your performance.

Getting it all down means you can perform at your best levels. Your endurance will be long lasting and you won't become as tired. You will have that extra edge when you need it most--whether it's the last few minutes of the contest or the last 10 meters before the finish line.

Remember to power up with good food every day so you can take full advantage of a well-hydrated body.

---

# Pre-Journey

---

## Stretching and Warmup

### Warmup

Canadian Community Dragon Boat Association

Warm-up before practices should be done not only to get blood into your muscles but also to prevent the tearing, ripping, straining and spraining, not to mention the multitude of other gruesome things that can happen to your body.

WARM-UP IS VERY IMPORTANT ... and while a practice session may incorporate a warm-up component it is vital for people who come late to be sufficiently prepared before they are committed to heavy work.

On the water, 5 minutes easy paddling followed by 5 minutes of medium effort work will be adequate, though everyone should have worked up a good sweat before turning up the intensity.

Land warm-up exercises are good including everything from push-ups and jumping jacks to a 10-20 minute jog, which should COME BEFORE stretching exercises!...(stretching a muscle which has not warmed up is like pulling on a frozen rubber band). A stretching regime is a generally a good habit even in the middle of a practice, though exercises should not incorporate bouncing which promotes hyper-extension All stretches should be held for a count of 30.

---

## Pre-launch Checklist

### Pre-Launch Inspection

Kihei Canoe Club

- 1 Watertight compartment forward, is empty and watertight
2. Watertight compartment aft, is empty and watertight
3. The hull is sound, no visible cracks or fractures to the fibreglass
4. Wae (structure to which the ama is secured) is sound, no cracks evident
5. Wae rigging lines are tight and secure - no frays evident
6. Seats (all 6) are serviceable and secure
- 7 Iako are sound - no cracks or de-lamination
8. Ama is sound- no visible cracks and it contains no water Lift the ama - if it is unusually heavy, it contains water..... Look at the bottom of the ama - that's where the cracks emerge
9. Ama lines (2 sets) are tight and secure - no frays evident.
10. 2 bailers in good condition are properly secured (lines are tucked, no knots)
11. Ensure that there is at least one spare paddle aboard

### Check Your Boat!

Vernon Racing Canoe Club

Before the canoe is put in the water, do a visual and physical inspection of the rope riggings. Ensure that they are tight. Try to wet the rigging so the ropes will contract and get tight.

If you find your rigging is loose at all, notify your steersman who will notify your coach.

Check your 'iako for cracks or structural weakness.

Check that bulkhead and ama plugs are in and tight.

Check that you have at least two bailers per boat. Each crew must be responsible to check to see that they have bailers in the boat before leaving shore. Tie at least one bailer to a rope on one of the 'iako.

If any of the canoes need rigging before practice, all paddlers should help.

If you do not know how to rig -- watch, learn, ask questions and try it the next time.

When returning from a practice, make sure all equipment is stored away properly.

### Check Your Equipment!

Waikiki Yacht Club Canoe Team

Once the canoe is in the water, do a visual and physical inspection of the rope riggings to make sure they are tight. Try to wet the rigging so the ropes will contract and get tight.

---

If you find your rigging is loose at all, notify your steersman who will notify your coach.

Each crew is also responsible to check to see that they have bailers in the boat before leaving shore. Tie at least one bailer to a rope on one of the 'iako.

After practice is finished and the boats are returned to the dock, crews should take turns rinsing the canoes (and especially the rigging) with fresh water (use the hoses at the dock).

If any of the canoes need rigging before practice, all paddlers should help. If you do not know how to rig -- watch, learn, ask questions and try it the next time.

### **Safety and Equipment**

Kent Island Outrigger Canoe Club

Safety First

The first and foremost rule of the club is to paddle safety. If there is any doubt about equipment conditions, water conditions, or paddler skills DO NOT TAKE ANY CHANCES. Stay ashore.

All paddlers must have a life jacket in the boat! Wear the lifejacket if it makes you more comfortable! If you are not a strong swimmer, be certain that the person paddling near you and the steersman are aware that you might need assistance if we huli.

Anyone with a medical problem that may arise during practice (including, but not limited to asthma, diabetes, heart complications, or special medication) needs to inform the coaches.

All paddlers must provide emergency contact information to the club officers. This includes name, relationship, and phone number.

Visually and physically inspect all the rope and snap lash riggings to be certain they are tight. Wet the rigging so the ropes will contract and tighten.

Two bailers should be in the boat. Tie the bailers to both 'iako so they do not float away if we huli.

The US Coast Guard requires that the canoe carry one PFD per person. Do not leave shore without them!

After practice is over, return the canoes to their tires, rinse off the canoes, especially the rigging, place the covers on the boats, and return the PFD's to the storage area.

### **Required Equipment**

Kawika Sands

- Personal Floatation Devices
- Emergency Signaling device
- Bailers

*PFDS*

To be legal (in the U.S., U.S. territories, etc.) you **MUST** have: One PFD for every person aboard, and a proper emergency signaling device. The PFD, or lifejacket/vest, is rather strait forward. You **MUST HAVE ONE FOR EVERY PERSON ABOARD!!!**

*EMERGENCY SIGNALING DEVICE*

What's "proper" depends on if it's day or night. The day/night flares make the most sense.

*BAILERS*

Minimally, there should be two bailers in the outrigger, at seats 3 and 5.

The bailers are to be kept in serviceable condition **AND** readily available for use!!! **NO TYING THEM DOWN** in such a way that they cannot be **EASILY** and **QUICKLY** used!

### **Recommended Equipment**

Kawika Sand

*VHF RADIO*

A VHF radio needn't be kept with EVERY outrigger, but at least one per practice should be included even if not far from shore! It's not that you couldn't **YELL** at someone ashore, it's so you can speak **DIRECTLY** with an emergency service (the Coast Guard) saving critical minutes.

*WHISTLE*

When interviewed, the base commander of a U.S. Coast Guard station reminded me of an incident where five people went into the water for many days after their boat sank. **SEVERAL** times rescuers passed within a few yards of them. Each time close enough to hear the conversations aboard and yet the rescuers neither saw nor **HEARD** them. Given fairly good conditions you must be about five yards away from the rescuers to be reasonably

---

sure of being spotted. FIVE YARDS! and you STILL may not be seen or heard! An emergency/survival whistle or horn can make you heard over wind, water, engines or distractions.

---

## Launching

### The Launch

Kihei Canoe Club

1. Plan your trip in advance considering - weather, swell, wind-driven chop, and daylight If you feel uncomfortable, in regard to any of the above - **DON'T GO OUT.**
  2. **Launch one canoe at a time** - remember the rules of the road above
  3. Observe the wave pattern - wait for a small set
  4. Lift the Ama - move the canoe towards the ocean - 'get it wet'.
  5. Start the launch, as the wave approaches the shore - "ready crew? - IMUA"
  6. Order all to paddle on the left - smartly, until 200 yards off the beach
  7. Steerer sits on the left gunwales until crew is seated and paddling on the left
  8. If you took on water during the launch, head into the sea, order seat 5 to bail
  9. Proceed with the paddling plan
-



# The Journey

---

## How to Paddle

### Padding Technique

Kent Island Outrigger Canoe Club

"AN EFFICIENT TECHNIQUE IS THE KEY TO ENJOYABLE AND FAST OUTRIGGER CANOEING. MARATHON AND OUTRIGGER RACERS WHO HAVE NOT ONLY TO SURVIVE MULTIPLE-HOUR RACES BUT TO FINISH STRONGLY, HAVE LEARNED A LOT ABOUT TAKING EFFICIENT STROKES.

"In any endurance sport efficiency is the key to getting the best results with the least amount of effort and of all canoeing, outrigger and marathon racing puts the highest premium on efficiency. Observing a canoe race, you'll notice the leaders go by looking relaxed and going fast. Sometimes they don't appear to be working very hard. Then the rest of the teams follow, each one going slower but appearing to be working much harder than the leaders. What's going on here? Do the leaders have a much faster canoe? The fact is, they are simply much more efficient in their technique than the teams which they are beating.

"Outrigger canoe racing is an endurance sport. The leaders of a cross-country ski race or a runner in a marathon or triathlon appear to be gliding along with minimal effort. Their motions are just enough to get the job done without wasting precious energy. Hence the rule in endurance sports: **WORKING HARD DOES NOT ENSURE THAT YOU ARE GOING TO GO FAST!**

"You can take your paddle and attack the water with it, straining every muscle in your body, throwing up big rooster-tails behind you, or you can slice your blade into the water, anchoring it solidly and using your entire torso, pulling it smoothly and evenly with much better results.

"Not only is good technique energy-saving and fast, it is easy to learn because it is so simple. Part of the learning process requires that you have a clear picture in your mind of how a paddler moves the canoe through the water.

**"THE CANOE IS BEING PULLED FORWARD THROUGH THE WATER UP TO THE PADDLE, WHICH ACTS AS AN ANCHOR IN-THE WATER (AKIN TO A MOUNTAINEER CLIMBING UPWARD WITH THEIR ICE AXE). THE CANOE IS BEING PULLED FORWARD NOT PUSHED."**

(The above material is excerpted from the 1995 edition of *Kanu Culture* by Steve West)

Remember to use your body in the stroke. Most new paddlers are all arms, attempting to generate all the power with the relatively small biceps and triceps muscles of the arms rather than using, in combination, the muscles of the torso and back which are far larger and more capable.

Having a good understanding of the proper technique and applying all your muscle groups will ensure prolonged and powerful paddling. You also need to understand and learn the proper techniques of entering and exiting your paddle blade and how and when to apply power.

### STROKE TECHNIQUE

The stroke is broken down into three phases:

#### 1. Catch Phase (Kau)

The catch is that portion of the stroke where you get the blade of the paddle into the water.

a. Lean slightly forward and using your stomach and back muscles rotate (twist) around your spine dropping your shoulder and extend the paddle forward keeping the shaft of the paddle parallel to the side of the canoe. (This twisting will enable you to use the larger and stronger muscles of your back and torso). Your lower arm should be fully extended with your elbow straight. Your top hand should be at your forehead with the arm fully extended and the elbow slightly bent.

b. Once you have extended the paddle (**reach**) place the blade cleanly in the water without stabbing or splashing. Do not start the power phase of the stroke until the blade is deeply in the water (this will cause cavitation and you will not get full power from your stroke).

If you slice the blade in cleanly and buried the whole blade in the water you will have a solid **ANCHOR** from which you can pull the canoe.

**REMEMBER A CLEAN SILENT ENTRY IS THE BEGINNING OF A GOOD STROKE. RUN SILENT, RUN DEEP.**

#### 2. Power Phase (Huki)

The power phase is that portion of the stroke where you move the canoe forward.

a. Make sure your body is firmly positioned in the canoe to fully transfer energy from the paddle to the canoe. You do not want any extra movement in your arms that will absorb or deflect energy from moving the canoe forward. (This is accomplished by keeping your arms in the entry position.)

---

- b. Push down and across your body with the top hand and untwist with an explosive movement driving down with your top hand and back on your lower hand to about your mid thigh.
- c. Once your lower hand has reached your mid thigh release power and begin the exit.

### 3. Recovery Phase

The recovery phase is that portion of the stroke where you get the blade out of the water and back to catch for the next stroke.

- a. Once the blade is at your mid thigh release power and either pull the blade straight out or slice it out to the side. This is done by rotating your top hand down similar to turning the steering wheel of a car.
- b. Float the blade forward through an easy return to the start of the next stroke. Remember to **feather** your blade during times of strong head winds. You feather the blade by turning it parallel to the water during the recovery, which will reduce drag.

Remember, the recovery should be easier and slower than the power phase. There should be a 2 to 1 ratio between the recovery/catch and power phase. One beat for the power phase and two beats for the recovery and catch.

#### *HELPFUL HINTS:*

Try paddling with locked elbows. This will force you to sit up and rotate. Add the minimum bend necessary to your arms for comfort later when you have mastered this.

Try to keep a flat back and keep your chin up, this will afford the maximum oxygen uptake and will help keep your shoulder and neck muscles relaxed.

Don't forget to get drive from your leading leg. Always keep the leg on your paddling side extended forward to help you brace - this means when you switch the paddle at a Hut, you must also switch which leg is forward.

Keep your face muscles relaxed and remember to breathe! Breathing in synchronization with your paddling helps you maintain an even stroke.

Keep your concentration in the canoe and remember that it is the thoughtful application of power that makes each and every stroke count.

Concentrate on your stroke technique at all times especially when you get tired. Your stroke is the first thing that will fall apart once you start getting tired.

Remember that the boat slows when the change is made, so make your last two and first two strokes on each side strong.

### **Paddling Technique**

Canadian Community Dragon Boat Association

A tremendous amount of controversy revolves around the optimum paddling 'style', which is often couched in as much mystery as that of the winged keel. The rudiments of outrigger paddling boat technique, however, are common to most forms of paddling, such as kayaking, marathon canoeing, dragonboating or even rowing for that matter.

Outrigger canoeing is most closely related to C1 canoeing which involves a very similar pattern of movement and is a useful comparison due to the large amount of research data available on this particular stroke.

The basis of a good paddling technique is the emphasis on 'the forward stroke' ie. applying power in the water in front of your body. Many good paddlers keep it to basics and will tell you to 'just get the paddle in deep and clean and pull like hell with lots of length, as many times as possible'. Though this may sound simple enough, there are a complex series of movements required to execute 'the forward stroke' efficiently and effectively.

Understanding the components of stroke technique is vital to accurate analysis of an individual's paddling style.

The four critical phases in the forward stroke are:

- the CATCH (anchoring the blade),
- COMPRESSION (the power phase),
- the FINISH (getting out of the water), and
- the RECOVERY (getting forward to a ready position).

The characteristics of different 'styles' may be due to variations in one or perhaps in every phase of the stroke, though the principles behind each phase are universal. We must accept that style may also vary from person to person depending on body size and stature which can work to the advantage of the team due to the different physical constraints of each seat position.

Equally important, we must recognize that 'style' changes as stroke rating increases and the stroke length is decreased. Many paddlers experience difficulties in attempting to apply the characteristics of a longer, slower technique to a faster rating.

---

A smooth running of the boat results from paddlers not only going into the water at the same time, but moving through each phase of the stroke in perfect unity. The complete stroke must also be seen as a cooperative product of its parts, executed in one unified motion, not as a series of independent movements.

Individual paddlers should create a mental image of each stroke phase both on the water and off, understanding its components intimately and how they effect performance. Analysis of technique can be made easier by isolating the disposition of the paddle in relation to the boat and by tracking key reference points on the body, namely the wrist, the elbow and the shoulder. It is useful for paddlers to know the position of these points relative to their own stroke and in relation to an ideal model.

#### THE CATCH

Few sounds on the water generate as much satisfaction as 20 paddles plunging into the water in time and without splash; except maybe that sound a high platform diver makes when they cut the water surface with nothing more than a ruffle of bubbles.

Burying the blade in the water is called the 'CATCH' and it should be well in front of your body critical to initiate a powerful stroke. This where most novice paddlers are the weakest and it is the point at which even veteran paddlers fail when they start losing power due to lack of conditioning. The most common problem is to lose length by catching the water too far back by not reaching far enough forward in the RECOVERY or start smacking the water with a misguided sense of aggression.

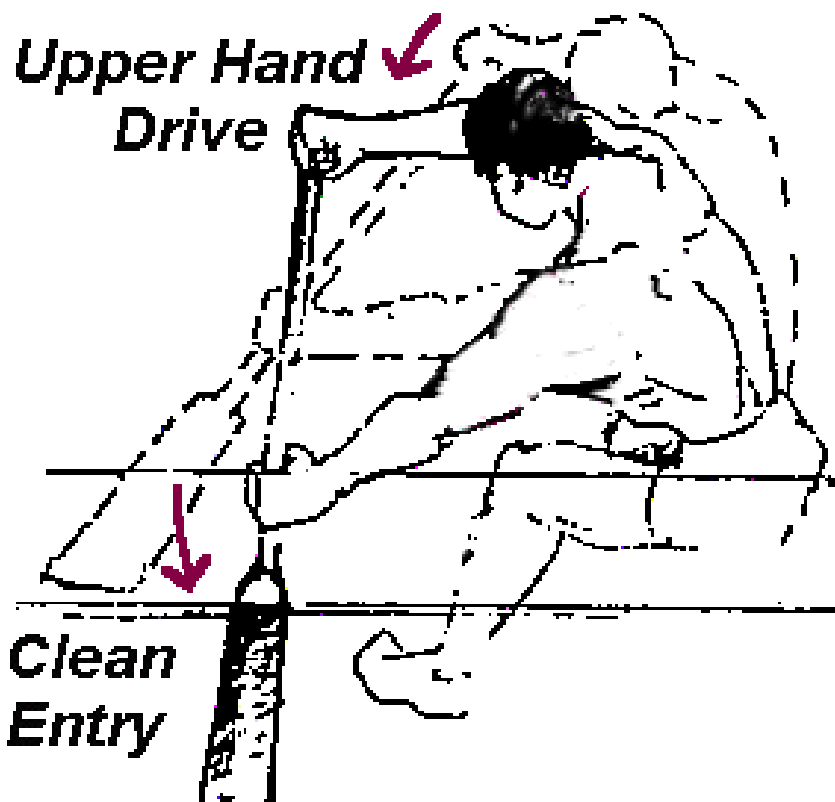

A good CATCH requires a deliberate and powerful drive downward by your top arm, which is made more effective when the wrist and elbow of your upper arm are above the inside shoulder making your forearm parallel to the water surface. Some teams utilize very high upper hands to emphasize a forceful drive into the water, though good control as the blade enters the water is important to avoid splash.

Good paddle entry is executed in either a vertical 'spearing' of the water or can be combined with a slightly diagonal 'slice' as the blade carves into the water. The slice is found to be very effective by locking the blade in fast and deep with less of a vertical lunge, though requires a greater participation from the bottom hand in combination with the upper arm drive. Your bottom arm must be fully extended forward, but not locked at the elbow to help ANCHOR the paddle in the water quickly and cleanly to its full depth and correct location relative to the side of the boat, without any splash or horizontal movement.

A common problem is that 'work' is often applied too late after the CATCH as a

paddler may be well into the first part of the STROKE phase before full power is exerted (wasted potential is a paddling sin). A good CATCH technique must transmit power into the STROKE phase within a fraction of a second. This is also important to unify CATCH in the boat in order to maximize POWER with each paddler transmitting power into the STROKE at the same time, which is not always apparent. Getting into the water at the same time is one thing; beginning to pull together is another and is vital to a fast boat.

Excess splash or cavitation in the water (trapped air and disturbed water) is an indication that you are applying power with the momentum of the vertical drive, before the paddle is fully buried (lost energy is another paddling sin). The paddle blade at entry should be moving forward at the same speed as the boat in order to avoid such splashing. Smacking the water too aggressively can result in broken paddles and can lead to tension when your teammate behind you receives an unwanted face full of water. This type of problem is often created by a misapplication of aggression and is usually an indication that a paddler is getting tired or is unable to keep up with the pace. The CATCH is not a power phase, it's how you get into the water. Keep it fast and keep it clean.

Another common mistake is to lunge too far forward with your upper body or to bend excessively at the waist which starts the boat bobbing up and down.

"You want to run a quiet boat. You want a smooth running boat. Every time the boat wiggles left or right or bobs up and down, you lose a little. This can play havoc with your speed and efficiency - be fast."

- Peter Heed

Remember that the length of 'the forward stroke' is controlled by a fully extended bottom arm and a rotated torso. You only need to bend far enough forward to bury the blade to its full depth at the CATCH.

Remember also, a powerful CATCH comes from a strong upper arm drive into the water at a forward position which is sharp, clean and instantly transmits power into the STROKE. Once the stroke rating increases to 90 plus, emphasis on the CATCH becomes more important in order to deliver power quickly.

#### COMPRESSION

Many paddlers think that they are pulling water past their bodies to make the boat move forward; but this doesn't make any sense at all. In fact, the paddle, once its in the water, moves very little in relation to a fixed point in space and that the boat is actually pulled up to this fixed point during the COMPRESSION phase.

This is the power phase and it is a full body endeavor which must coordinate arm, leg and torso muscles into a singular and controlled movement, transmitting power into a linear forward direction. Keeping the paddle relatively vertical and anchored in the water with the arms a paddler must use his/her torso to pull the boat forward. If too much enthusiasm results in pulling the paddle back through the water then energy is lost and a great turgid froth without much forward motion usually results. Much depends on a good solid CATCH, and the rest depends on solid control of power expenditure that accelerates the boat forward.

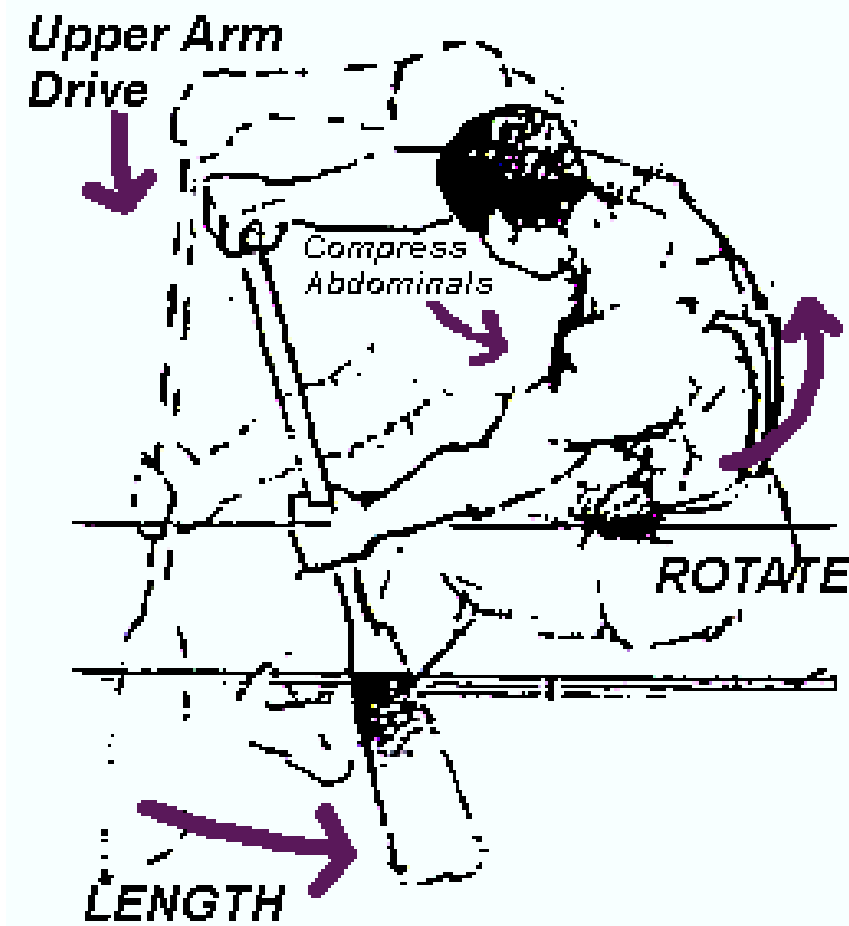

It helps to imagine that you are hurtling your body up and over the CATCH position by pressing the paddle vertically down. This requires a smooth and continuous motion compressing shoulders downward by crunching your abdominal muscles, at the same time rotating the torso at the waist utilizing the large back muscles i.e. Lats. and Erectors. The upper arm must continue to be held high and drive down with the shoulders to keep the blade locked into its position in the water as the stroke develops. A minor forward push of the upper arm will transmit additional power into the paddle with your Deltoids and Pectorals, however you must keep the fulcrum point of the paddle high, about six inches below the upper hand 'T' piece.

The bottom arm must be strong to keep the blade on a straight track and transmit the power from the torso into the paddle, and will only bend slightly to push the FINISH of the stroke with your Biceps.

Following this motion, the paddle works as a third class lever, with the upper hand remaining relatively fixed with the vertical drive of the shoulders and rotation of the torso providing force.

Very often, paddlers get into the habit of pushing their upper arm over and downwards at the CATCH, thereby lowering the paddle fulcrum point to the location of their lower hand. The upper hand during this phase should not drop below your shoulders and your forearm should remain parallel to the water surface.

Another problem is that the paddle blade is often not deep enough to maximize the resistance area, particularly at the front end of the COMPRESSION phase. The paddler must bend forward to keep the blade buried right up to the shaft. Very often paddlers will also begin to lift their blades gradually out of the water towards the FINISH, which can be seen as their bottom hands rise in relation to the gunwale, starting midway through the stroke. Focusing on a good top arm drive and curling the torso over with your Abdominals to keep the paddle in the water will help.

Adding power to the end of the compression phase relies on a deliberate push just before the FINISH. The paddle must be kept as vertical as possible with forceful upper arm drive downward, as if you were attempting to

plant the paddle straight into the ocean bed. This takes tremendous focus to do it well and do it consistently. Efforts must be made to train the deltoids and pectorals to deliver power at this part of the stroke.

"Keep the paddle vertical during the power phase. The paddle should be in line with the keel line of the (boat). Too often, paddlers tend to follow the side of the (boat) with their paddle. Bow persons' paddle should enter the water away from the sides of the boat and come in so the paddle nearly touches the boat at recovery. Stern paddlers do just the opposite, planting the paddle right beside the boat and coming straight back."

- Peter Heed

The legs play a much more critical role than one would think as they are used to push the boat forward and lock the body into your seat. They must anchor the body into the boat to the point that your knees can suffer severe strain. Ideally all paddlers should align their outside legs against the gunwale and outside foot rest (or seat in front) so that a continuous line on force is directed into the boat. The inside leg should be tucked under the seat with the knee braced against the inside spine of the boat, which helps lock the body in and assist in an easier rotation. Sitting slightly forward to hang over the front edge of the seat will also help to lock in and provide resistance to the forward motion of the recovery.

#### THE FINISH

The power stroke is brought to an end when the elbow of the lower arm is aligned with body and the shoulders are parallel to the seat i.e. *the neutral position*, with the blade still fully in the water. Any power applied after this point, which is certainly possible, results from over-rotating the torso and more often will create a lifting

force due to the angle of the paddle that will pull the boat down into the water and/or will ship water into the boat. This is an important point since the body is capable of exerting force beyond the neutral position, however, it is not an energy expenditure which will contribute effectively to the forward motion of the boat.

The paddle should be slipped diagonally up and out of the water leading with the upper hand as quickly and cleanly as possible with minimum resistance or splash (Deltoids). Many teams emphasize lifting the paddle high with the upper hand to keep the paddle as vertical as possible. This is good in flat water conditions and in boats with close seat spacing as it allows a paddler to reach up and around the paddler in front.

A common problem is that the FINISH is either initiated too early particularly when the stroke rating is high, or lacks any clear definition as the paddler begins to lift his blade out of the water half way through the COMPRESSION phase. It is imperative that the paddler focuses on keeping the blade deep in the water and applying full power to the stroke right through to the FINISH position. Think of the vertical upper arm drive!

It's worthwhile to focus on a 'power punch' at the FINISH to provide a kick at the end of the stroke similar to the aggressive CATCH at the beginning. To achieve this, the outside elbow should be kept close to the body and the paddle blade should be

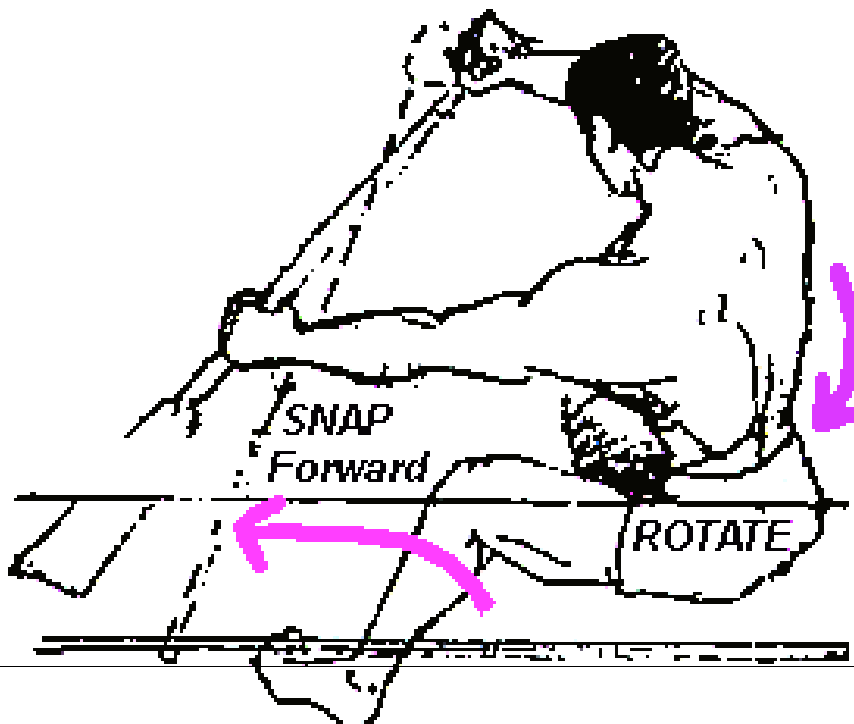
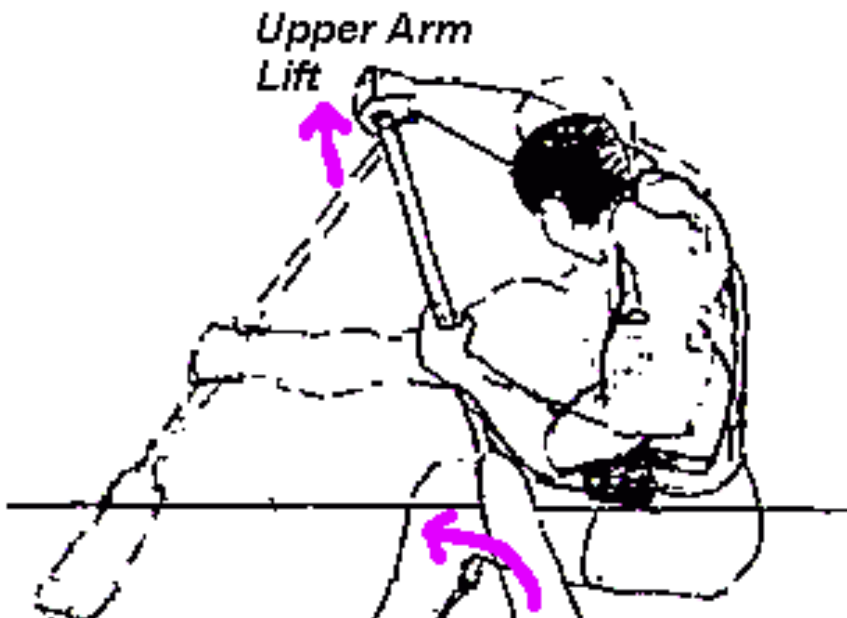

feathered out with a powerful kick from the forearms and biceps. The paddle should be brought out fast and high to avoid drag and to initiate a speedy RECOVERY. This will also help to push water away from the boat as the blade exits.

The FINISH should be executed with the same aggression and precision as the CATCH, and with the same timing throughout the boat.

*THE RECOVERY*

The RECOVERY is the key to the forward stroke technique as it sets up the CATCH well forward of the torso.

The most efficient RECOVERY is achieved by rotating the torso to push the outside shoulder straight forward while the inside shoulder is pulled to the back ie. in reverse of the STROKE. The lower arm must punch forward to create a long 'reach' while the upper arm is pulled the opposite direction and thrown back over the head to open up the chest.

This must be a quick and snappy motion since it is effectively 'down time' - when energy is not spent moving the boat forward; ie. the less time it takes 'get up front' the more time a paddler can spend pulling the boat. A fast recovery must be trained since it makes great demands on the Abdominal muscles, Deltoids and Traps, different from the efforts needed in the COMPRESSION phase. The key to a higher rating is a faster RECOVERY which allows stroke length to be maintained.

Precise timing in the boat is controlled by a coordinated RECOVERY where each paddler must execute a sharp and deliberate snap forward with the lower arm pushed from the shoulder.

Remember, a clean recovery is executed in a snap forward motion and is not achieved very well if the outside arm is carving great circles in the air. It is a relatively straight linear movement forward aligning with all other paddles in the team with outside elbows and paddle blades kept close to the gunwale.

A slight pause before the CATCH phase will mark both the end of the full stroke cycle and will help to synchronize the timing of the team; though at a high rating the 'pause' is more of a mental punctuation mark than any noticeable lapse in time

Though the movement forward should kept 'bright and crisp' the paddle should be held lightly to relax forearm muscles. Very often paddlers exert too much power getting forward. The RECOVERY should be fast but light. Over time it will become effortless movement, but it takes a lot of work to achieve speed and should not be neglected as part of a training regime.

Boat speed in the RECOVERY phase will slow down obviously due to the break in paddling, though the rate of deceleration know as the Check can vary from team to team as a result of different technique. As paddlers move forward, their centre of gravity (CG) can also move forward causing the boat to decelerate more. Strangely enough the boat will actually accelerate slightly on its own at the end of the RECOVERY phase once the paddler's forward movement ceases. In this respect, you should focus on minimal movement of the CG in the RECOVERY, and confine that movement to a forward and backward line, not up and down or side to side.

One common problem is that the upper arm is allowed to drop too much resulting in a horizontal RECOVERY. In a tight boat, this will be problematic and will also begin to hamper efforts to increase rating.

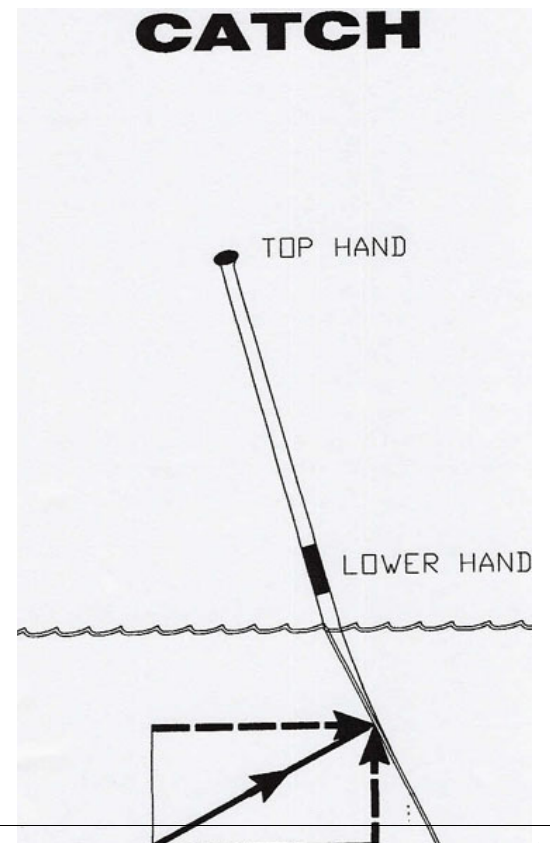
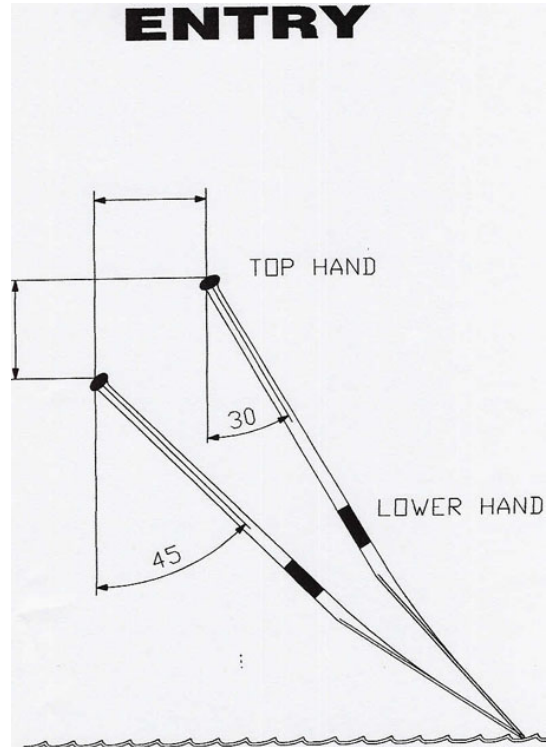



Bending the upper arm also leads to excessive movement which will limit performance at a higher rating and can cause the boat to jump around a lot. Neither the upper or lower arm needs to flex very much in the RECOVERY, or for any phase for that matter.

### Variations in Stroke Technique

Canadian Community Dragon Boat Association

As previously mentioned, stroke technique will vary slightly from person to person due in a large part to differences in physiology and training background, and should be tolerated to a certain degree, particularly at a local race level. While it is important to have everyone paddling the same technique, it is more important to ensure that each paddler is contributing to his or her highest potential. Even the best teams in the world show a variation in individual technique yet they all pull a lot of water and win.

The critical issue is that each paddler hits each phase of the stroke with precise timing and that the movement front to back and side to side are consistent throughout the boat to maintain balance and smooth running. Even though paddlers may have slight differences in form, ie. some rotating more or others with a slightly higher blade on recovery, if everyone is executing each phase correctly and in time, it is doubtful that efforts spent on minor adjustments for the sake of consistency make any significant difference in boat speed.

It is more important to focus on the smooth transition of power from one phase of the stroke to the next and that the delivery of power is timed perfectly for each paddler at every point in the stroke.

The basics of technique that establish consistency among team members are recapped as follows:

- the consistent location of the CATCH and FINISH
- minimal splash or lifting of water
- uniform speed of RECOVERY and STROKE (some people move faster than others)
- uniform depth of paddle in the water
- uniform angle of the paddle as it moves through each phase
- the precise timing at which each phase is initiated
- the alignment of paddles with the direction of travel
- the elimination of excessive movement (bobbing your head up and down or side to side will not improve performance and only waste energy)
- fluid and unbroken movement through each phase
- uniform breathing pattern

The nature of the boat can also effect the characteristic of stroke technique due to shorter seat spacing, higher gunwales, the weigh of the boat or the size of the paddles. It is imperative to 'test' out a race boat by varying stroke length and rating to find the most effective combination to make the particular craft move the fastest. For example, an eight man colour boat responds much better to a longer stroke with a greater emphasis on a drawn out kicked finish, compared to a quicker dragonboat stroke.

Natural elements such as tide, wind or water conditions will impact on technique. Racing with a tailwind for instance should increase boat speed and allow for an increased stroke rating, whereas rating should decrease and a greater stroke length should be implemented when heading into a wind.

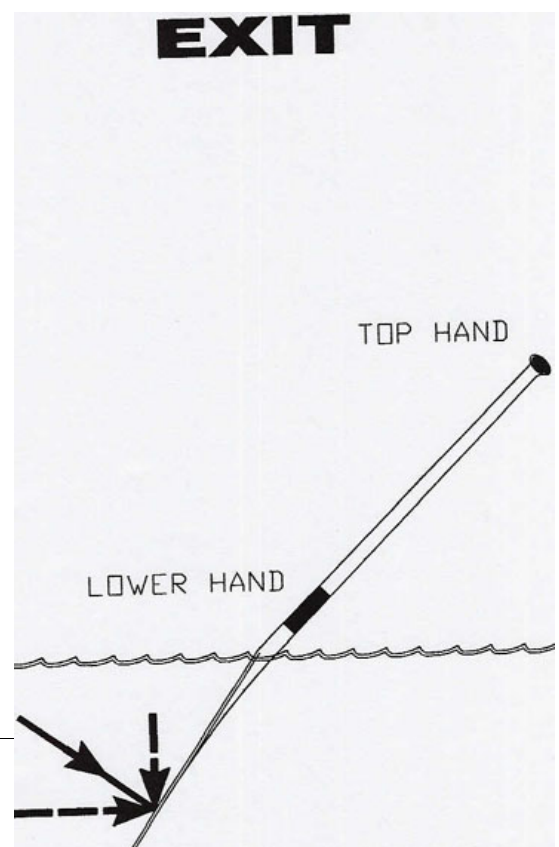
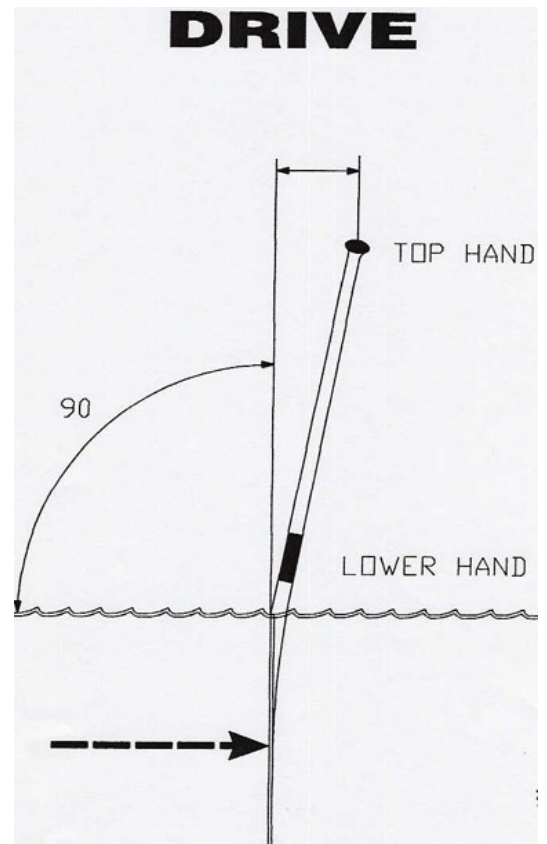

In choppy water it is important to have paddle blades higher on the recovery and to emphasize greater depth in the water to avoid going in too 'short' when a wave trough is encountered. Choppy water will also slow the boat down so it is important to be able to adjust stroke rating in order to suit the abilities of the crew to the particular conditions experience.

**Technique**

O Kalani Outrigger Canoe Club

**LESSON #1**

You get the reach by twisting. Lead with your shoulder. Lower arm extended.

Catch the water then apply power by pushing down as you twist back upright.

Do not stab the water.

Pull with a full blade along the side of the canoe.

**LESSON #2**

Reach by twisting. If you get your reach by bending you won't be pulling through the water and you will cause the canoe to bounce.

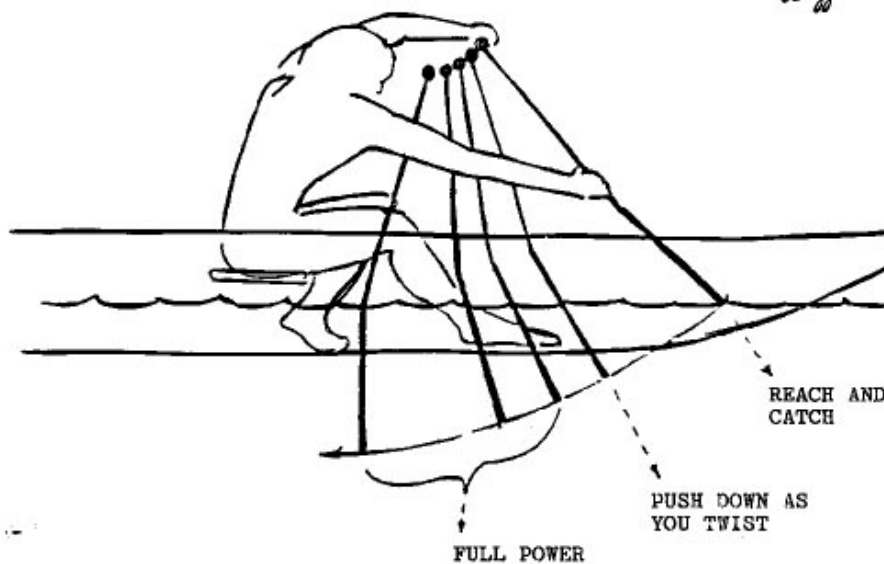



RIGHT

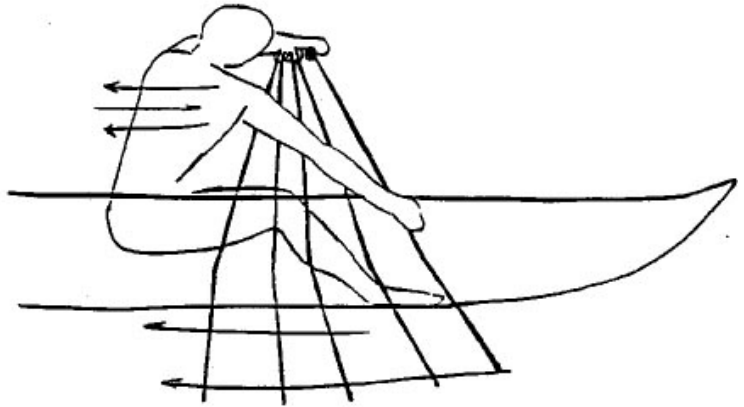

WRONG

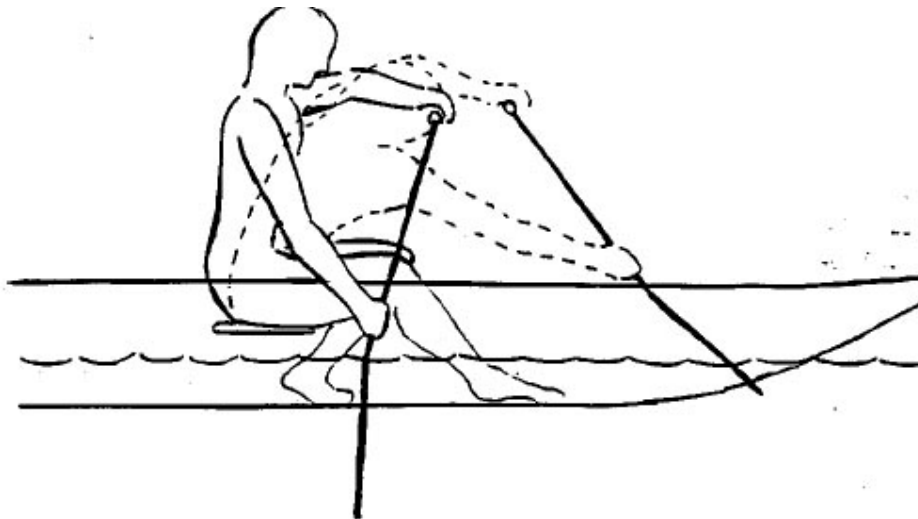
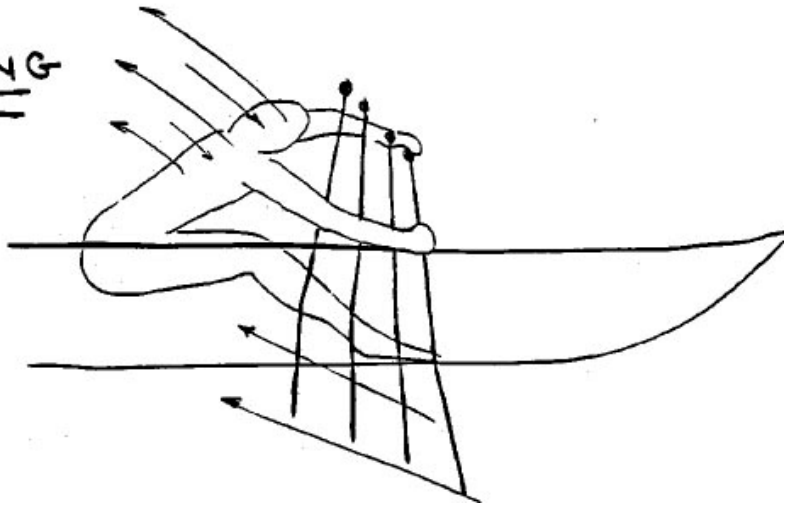

### LESSON #3

If you bend your lower arm too soon you will tire more rapidly and lose power by using your arm muscles instead of the muscles in your back.

You bend your arm to release the paddle from the water at the end of your stroke. If you bend your arm during the stroke the paddle will start to come out of the water and you will lose the pulling surface of the blade.

#### WHY ANGLE A PADDLE BLADE?

You can pull further back before you have a verticle blade, with more power through the water.

You get more reach in front of the stroke.

*STROKE & TECHNIQUE*

(O Kalani Outrigger Canoe Club)

From Andy Torro's Stroke & Technique class at the 2003 NCOCA Race Clinic.

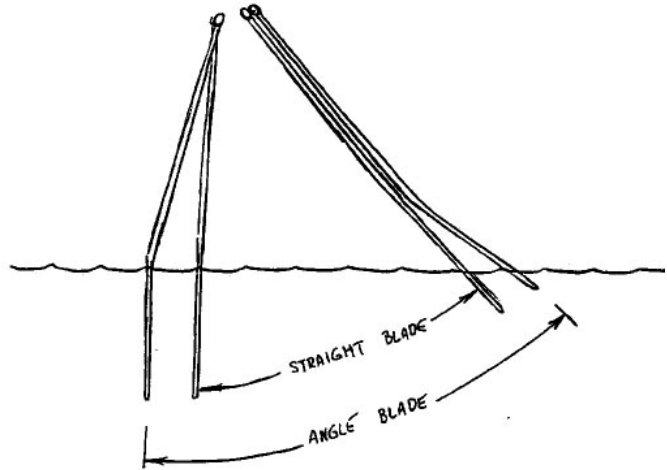

---

## Seat Roles

### Outrigger Seat Jobs

Vernon Racing Canoe Club

Seat 1 sets the pace and the stroke. Seat 1 must maintain a good "feel" for the movement (glide) of the canoe, and adjust the pace accordingly. This means watching the water ahead, and paying attention to the feel of the boat. Seat 1 also changes the rate depending upon the conditions. This seat will often have a paddle 1/4" to 1/2" shorter than the back seats.

Seat 2 is responsible to work with Seat 1 maintaining the timing of the boat on the opposite side. Seat 2 will mirror Seat 1 in timing and stroke length. Seat 2 should be watching the water with Seat 1 and quietly communicating with them to confirm how the boat feels, stroke rate and length.

Seat 1 and 2 should establish short signals such as, "reach" for a longer stroke rate, "up" for increased rate, and others, as needed. If Seat 1 disagrees, say "NO".

Seat 3 (in VRCC) calls changes and always be aware of what is happening around the canoe (in order adjust stroke count). There will be times when the count must change - stay on one side to prepare for a turn, start sequences, riding waves, etc.

Seats 4/5 power the boat and maintain balance.

Seat 5 may be required to assist the steersperson in difficult water.

Seat 5 and Seat 6 must quietly communicate and work together.

Seat 4 is also the bailer, as required and watches the ama in rough water. Seat 4 must also pass messages up the boat.

When the crew shoves off, Seat 6 is responsible AND liable. Seat 6 first responsibility is crew safety; second - canoe safety; third is steering and navigation and fourth - keep the crew in time, focused and motivated. After that, Seat 6 is a paddler.

An additional responsibility of Seats 2 & 4 is to watch the 'iako. (Always lean back and out on the 'iako whenever the canoe is at rest and be "ama conscious" when the canoe is moving.)

An additional responsibility of Seats 3 & 5 is to steady the canoe. Seats 3 and 5 must also pass along commands from the Steersperson, if necessary. The steersman is always in command of the canoe, however, everyone is responsible for the safety of the crew and the safety of the boat.

### Seat Jobs

Waikiki Yacht Club Canoe Team

What is the main responsibility of Seat 1? **set the pace/stroke**

What is the main responsibility of Seat 2? **call changes**

What are the main responsibilities of Seats 3, 4 and 5? **power the boat**

What is the main responsibility of Seat 6? **steer**

What are the additional responsibilities of Seats 2 & 4? **watch the 'iako**

What are the additional responsibilities of Seat 1? maintain a good "feel" for the movement (glide) of the canoe, and adjust the pace accordingly.

What are the additional responsibilities of Seats 3 & 5? **steady the canoe**

What are the additional responsibilities of Seat 6? **keep the crew in time and focused**

---

### Who Does What and Why?

Kent Island Outrigger Canoe Club

- Seat 1 (Stroke)** Sets a consistent pace and keeps the strokes long; the rate varies from 60-70 strokes/minute depending on conditions. Has a natural sense of timing and rhythm and is aware of where the boat, the crew, and water are at all times.
- Seat 2** Supports seat 1 and keeps the opposite side of boat in sync by mirroring seat 1. Alternate to Seat 3 in calling changes. Watches the ama especially when the canoe is stopped. Like seat 1, has good sense of timing and can mirror the body movements of seat 1. Keeps 1 motivated.
- \*\*Not only must the stroke *rate* set by seat 1 be matched by every paddler in the canoe, but the stroke *form* needs to be the same throughout the canoe. Entering and exiting the water at the same time ensures that power distribution remains equal and synchronized throughout the canoe.\*\***
- Seat 3 (Caller)** Power seat. Calls changes, can alternate with Seat 2 if needed.
- Seat 4** Power seat. Watches the 'iako in rough water. Bails the boat when needed ("lowest" point of boat at 4). The heaviest and strongest paddlers keep the canoe stabilized.
- Seat 5** Power seat, watches ama; may share bailing duties if needed. May assist in steering in rough conditions. All around paddler who is able to work in concert with steer.
- Seat 6 (Steersman)** Boat captain when underway. Moves canoe in the desired direction, keeps crew focused and in time. Has excellent water skills and knowledge. Is responsible for overall boat safety.

### Six Paddlers in the Canoe - Who Does What?

(O Kalani Outrigger Canoe Club)

Six paddlers in the canoe all working in unison, but each with a role to play. Each paddler from seat number 1 through 5 paddles alternately on the opposite side from each other.

#### *SEATS ONE (STROKER) AND TWO:*

The Stroker sits in the very front seat of the canoe. Paddlers in seats one and two are primarily concerned with ensuring the rhythm and pace of the paddle strokes which seats three through five will follow.

They paddle on opposite sides and as such neither has a paddle to follow. The Stroker at the front of the canoe must set a more or less consistent pace which varies according to the nature of the race and water conditions. The paddler behind in number two seat must follow in perfect time mirroring the Stroker's pace so as the power distribution remains equal and synchronized down the length of the canoe.

The Stroker's job is crucial in ensuring the consistency of the crew working at an optimum pace and rhythm. When rounding markers, the Stroker and seat number two work together to turn the front of the canoe.

#### *SEATS THREE AND FOUR:*

Often referred to as the power seats or the "Engine Room", the heavier, stronger paddlers will generally take these positions. It is their primary task to provide the brute power required to push the canoe along. Number four seat generally takes responsibility for ensuring the canoe remains as dry as possible, bailing water when needed.

#### *SEAT FIVE:*

Again, a power seat they also need to have knowledge of steering to assist the Steerer when necessary. They are also referred to as the keeper of the Ama. This entails that they must eyeball the Ama (the outer float) to make sure it is stable. If it looks at any time to be lifting and threatening to capsize (Huli), they must quickly react to save it. Failing this, numbers three and four need to recognize the predicament and also try to save a Huli. Number five must also take responsibility for bailing should there be an excess of water in the canoe as by the time water is collecting towards the aft end of the canoe, there is definitely too much water onboard.

#### *SEAT SIX (THE STEERER):*

The Steerer, who is ideally the captain of the canoe calls the shots, motivates the crew and sets the canoe up for the best course and catching the swells. They plan and navigate a course and have a big responsibility during sprint races as they must set the canoe up for a good turn around the buoys.

They need to have a good paddling relationship with seat five in protecting the Ama and indeed with all the crew. Steering a 45ft/400lb canoe on the open ocean in rough water is an art form. Those that learn their trade well can be considered masters of a task which requires intimate understanding of the dynamics of the ocean and the nuances of the canoe and crew.

### What are the characteristics of a good Stroker?

Being Stroker is first and foremost psychologically challenging as they have the position of not being able to follow anyone and must therefore remain at all times self motivated and alert. In many respects their role is mentally more challenging than any other in the canoe, with the exception of the Steerer.

They must have a natural sense of timing and rhythm and have "eyes in the backs of their heads", being able to intuitively feel how the canoe is traveling and respond by increasing and decreasing the stroke rate where necessary. They need to be aerobically very fit as they may not pull as much water as those behind but they will be working hard on an aerobic level. Above all they need to be good natural athletes with a capacity to read the water and have an understanding of what the paddlers behind can tolerate as an effective, efficient stroke rate.

*WHAT ARE THE CHARACTERISTICS OF A GOOD NUMBER SEAT TWO PADDLER?*

Much like the stroker, a good sense of timing and rhythm. It is crucial that number two stay in time with the Stroker, made all the harder by the fact that they cannot actually follow a blade in front of them, but only the paddlers body movement. Number two needs to talk to the Stroker to encourage and keep them on task at all times. A good paddling relationship at the front of the canoe will ensure the rest of the canoe is firing well. Numbers one and two are the source of all that happens in the front which then travels back to the other paddlers.

Number two takes responsibility for counting the number of strokes per side and calling out when it is time to switch sides (around 15 - 20 strokes). They should also note how the stroke rate is going, in terms of number per minute, and therefore can they can prompt the Stroker if the rate seems too slow or too fast.

*WHY ARE PADDLERS THREE AND FOUR OFTEN THE HEAVIEST AND STRONGEST PADDLERS?*

In order to create a stable canoe, it is preferable to have your heaviest paddlers in the middle of the canoe between the two spars (Iako). In this way their weight stabilizes the canoe by ensuring that it sits reasonably deep in this mid section and therefore that the float (Ama) on the outer spar (Iako) maintains contact with the water.

Ideally seat three and four need to be concerned with little else, other than following the front two paddlers and applying maximum leverage. Beyond this the canoe is widest at its mid point and therefore physically large paddlers can fit in these seats but often have trouble fitting into seats one or two as the canoe is more narrow up front.

*WHY DOES NUMBER FOUR TAKE RESPONSIBILITY FOR BAILING?*

When water enters the canoe it will tend to pool first of all in the mid-section of the canoe. Number four can recognize this and react by bailing. They can also sit up on the spar (Iako) to do so, so that the canoe remains stable while they do this.

*SO WHEN DOES NUMBER FIVE BAIL?*

When there is a serious amount of water and the pool has extended to the rear of the canoe.

*WHAT ARE THE CHARACTERISTICS OF A GOOD NUMBER FIVE PADDLER?*

The number five paddler has a varied role and perhaps needs to be the most all around paddler. They should ideally be competent Steerers and of course strong paddlers. They need to be able to be totally flexible in their paddling ability, so as they can eyeball the Ama and protect it and change paddling sides rapidly and frequently if need be. They may also need to paddle for long stretches at a time, much like the Steerer, on the left side to protect the Ama, so as the steerer can concentrate on steering. Their reactions must at all times be fully intuitive, working in with the Steerer when it is needed. Also, new and inexperienced paddlers will generally be placed in this seat as there will be no paddlers behind them to be effected by their learning curve.

*WHAT ARE THE CHARACTERISTICS OF A GOOD STEERER?*

The Steerer has without question the greatest degree of responsibility within the canoe and one that is often overlooked by other paddlers. They must steer a good course, read the ocean and work the canoe so it interacts and travels at its maximum potential at all times. They most motivate the crew, call changes to stroke rates if they feel it necessary and ensure the overall safety of the canoe.

Experience counts for a lot in this position. Time on the water in all conditions is a must and an intuitive understanding of ocean dynamics is crucial to achieving maximum canoe speed. In this respect it is said that surfers often make the best Steerers. The best Steerers happen also to be excellent solo outrigger canoeists.

*HOW IMPORTANT ARE TIMING AND RHYTHM TO THE CREW'S PERFORMANCE?*

One of the fundamental secrets to making an outrigger canoe travel well, is precision of the crews timing and rhythm. ALL paddles entering and exiting the water at the same time, ALL paddlers pulling in unison and ALL using the same technique. The power from the paddles which travels from the paddle along the paddlers arms to their butts, is what drives the canoe forward and the power surge must be synchronized. Time in the canoe as a crew and working on these fundamentals are paramount.

---

### Canoe Responsibility Basics

(CORA)

These traditions insure respect and harmony in the boat.

Seat 6: Steersman

The Steersman is in charge of the boat. Responsibility for the crew's safety is of primary importance. Before going out s/he should:

- 1. Check that the boat has 2 bailers
  - 2. Check the rigging is tight, fore and aft plugs are in and there is no puka in the ama or canoe..
  - 3. Do not take the boat out if you are not sure that your skills are up to safely handling the weather and sea conditions! (Unless you have a more experienced coach or steersman to help.)
  - 4. Assign seats. Be sure to rotate seats so that each paddler learns each seat.
  - 5. Tell the crew what the plan is. (Where they are going, etc.)
  - 6. When the wind is up, hug the shoreline and stay with the other canoes.
- 

## Communication Protocol in the Boat

Vernon Racing Canoe Club

While paddling in both Outrigger and Dragon Boat there is appropriate communication standards that should be followed. These standards make sense to realize maximum team performance and minimum team stress!

The following are parameters we all should follow.

The Steersperson	Similar to DB, this is the only person in the boat other than the coach who should be giving orders or directions. Only he/she calls timing, calls paddles up, asks for draws left and right, rate changes etc.
Five Seat	Five seat can quietly communicate with the steersperson to assist in guarding the Ama. Five may be asked to pass on messages up the boat if the steersperson is looking to give direction in a way that can not be heard by other crews.
Four Seat	Can take over the count if three seat or six requests them to do so. Can also call "Ama" if they see a problem coming. Calls "Four bailing" when out to bail.
Three seat	Three seat calls the Hut for the team in VRCC. Some other clubs use Two or One. We prefer three as they are more central to the boat and it allows two and three to focus on their duties. Three seat may adjust the stroke count on their own choice based preparing the team for a buoy turn or in attempt to get one three and five on Ama side to stabilize the boat.
Two seat	Communicates quite encouragement to one seat. Two seat may asked one seat to consider an adjustment in rate or stroke style depending on the feel of the boat. These requests are suggestions only. One seat will ultimately decide along with six if a change is warranted. Two seat will also pass on messages sent up from six seat via the back of the boat.
One seat	One seat does not need to talk to anyone other than two seat. He/she may ask two seat for advice on the feel of the boat or she may ask for a message to be passed back to six seat if she is considering a change that six should be aware of. One seat should have some "secret" signals developed with her team to indicate, upping the rate, increasing the intensity for a pass (Pauline's "Grunt"), lower rate more power and other such strategy signals.

No one other than six seat and the coach should be giving directions in the boat. They are the only ones who can call "timing" comment on technique.

All others in the boat should only be offering positive encouragement to their fellow paddlers.

It is also frowned upon by fellow team mates if you are able to recite your weeks activities during a hard training or race situation! If you are able to say more the two or three words under these conditions you are probably not working hard enough.

---

## Commands

### Common Commands

Waikiki Yacht Club Canoe Team

---

When you hear "PADDLES UP" you should: lift paddle to "set" position.

To "HOLD WATER" you put your paddle in the water and hold it there to stop the canoe.

You usually "BACK PADDLE" to park the canoe or maneuver into position.

Your steersman will call "TIMING" when paddlers are not pulling together.

#### **Boat Command**

Kent Island Outrigger Canoe Club

Other than change calls, all commands will be called by seat 6, the steersman (**ho'okele**). The steersman is in charge of the canoe at all times.

#### **Steersman's Commands:**

"Paddles Up"

Seats 1 - 5 lift their paddles out of the water and rest them on your lap or across the gunnels.

"Paddles Across," "Paddles Set," "Paddle Easy," *or* "Hit"

This sequence occurs to get the canoe started.

*Paddles Across* indicates that all paddlers should place their paddles across the gunnels on the correct side of the canoe—odd seats on the left, even seats on the right.

*Paddles Set* indicates that seats 1 - 5 should lift their paddles in the set position.

*Paddle Easy* means to begin paddling in time with seat 1. Paddle Easy is used for warm up, while.

*Hit* is used to start a race.

"Hold Water"

Seats 1 - 5 place their paddles in the water perpendicular to the hull, holding the paddle in place to slow or stop the canoe. Brace against the hull and the gunnels.

"Back Paddle"

This is used for maneuvering the boat into position, usually when coming ashore or lining up for a race. Seats 1 - 5 paddle backwards in time. Be certain to turn your paddle so it is angled backwards. Your blade is stronger this way and you won't risk breaking it.

"Timing"

The steersman will call "timing" (**makia**/ focus) when the paddlers' strokes are out of sync.

"Power 10"

The steersman calls for higher power strokes to get the hull speed up. These are limited to 10 strokes each side for the number of sets requested by the steersman.

"Kahe Hema" (Crab Left)

Seat 1, and sometimes 2, reaches out to the left, plants the paddle blade deep in the water, and pulls the bow to the left. This assists the steersman in getting the boat turned.

"Kahe Akau" (Crank Right)

Seats 1 and 2 pull the canoe to the left or crank the canoe to the right. **DO NOT PULL TO THE RIGHT. YOU RISK HULI-ING THE BOAT!**

"Uni"

This is the first of two commands used for racing turns around buoys or other obstacles. Seat 1 holds (i.e., pokes) his/her paddle at an angle against the right side of the canoe. This action will move the nose of the canoe to the left. Seat 2 pulls left at the same time. All other seats paddle normally.

"Kahe"

This is the second of the two commands used in a racing turn. Upon hearing the steersman call Kahe, seat 1 comes across from the right side to the left side and joins seat 2 in pulling (or "crabbing") left. As soon as the canoe is almost out of the turn, the caller calls a Hut and everyone except seat 1 switches sides. The caller then calls another Hut in 10 strokes or so, so seat 1 can switch sides and get relief.

#### **Caller's Commands**

The caller, or **kahea**, (typically seat 3) ensures changes are made from one side of the canoe to the other to keep the paddlers from overtiring. The steersman may override the caller at her/his discrepancy. For example, the steersman feels the need to avoid huli and calls, "hoe ama" (everyone paddle left side) or needs to get the hull speed up and calls "2 sets, power 10."

"HUT!"..."HO!"

---

### **Additional Commands**

Vernon Racing Canoe Club

When the steersman calls "UNI RIGHT," the person in seat one holds the paddle against the RIGHT side of the canoe -- creating resistance on the right side of the boat. This action will move the nose of the canoe to the left. All other paddlers should paddle normally. (Conversely, UNI LEFT or KICK LEFT will push the nose to the right.)

On the command "DRAW LEFT" seats 1 & 2 lean out to the left and pull canoe to the left.

You should never "DRAW RIGHT!" (note, if your steersman wants help moving the boat to the right, seats 1&2 may "Uni Left" which moves the nose to the right.)

To "HOLD WATER" or "HOLD THE BOAT" you put your paddle in the water and hold it there to stop the canoe.

You usually "BACK PADDLE" to park the canoe or maneuver into position.

Your steersman will call "TIMING" when paddlers are not pulling together.

When you hear "PADDLES UP" you should: lift paddle to "set" position.

Some steerspersons may call "Ready All," or just "SET"

In Hawaiian, "IMUA" means Go Forward and "HUKI" means Pull. Either of these commands may be used in place of "hit" as a command to begin paddling.

"TAKE IT AWAY" is also a common start command.

The command to stop paddling may be "HOLD UP," "HOLD," "EASY" or other variations.

---

## Some Likely Problems

---

### Canoe Takes on Water

Kihei Canoe Club

1. Order seat 5, and if need be, seat 3 to bail too
  2. Caution, **the vessel is unstable** - remind the crew to lean towards the ama
  3. Turn and hold (light paddle) the canoe headed into the sea, until most water is removed
  4. Seat 3 resumes paddling; seat 5 finishes bailing
- 

### Canoe Swamps Next to Beach

Kihei Canoe Club

1. Drag/push the canoe as high up the beach as possible (it's very heavy)
  2. Instruct 2 crew members to lift the ama until the iako are vertical
  3. As an outgoing wave recedes, lower the ama to right the canoe
  4. Push/drag the canoe fully onto the beach
  5. Bail until the canoe is free of water
- 

### Ama Lifts (canoe is headed for a huli)

Kihei Canoe Club

1. Seat 5 shouts "A M A" and lunges for the aft iako
  2. Upon hearing the alarm, seat 3 lunges for the forward iako
  3. The remaining crew all lean towards the ama
- 

## Huli!

### The Huli

Kihei Canoe Club

1. A huli usually (almost always) results from a trained steerer's failure to communicate with his crew.....

#### HULI RECOVERY

1. Locate (and keep track of) each crew member in the water
2. Remind the crew to - **HOLD ON TO THE BOAT**
3. If a crew member is injured - assign another crew member to stay with him
4. The following crew assignments are *normally ordered*
  - seat 1 collects the paddles
  - all others, 'swim' the canoe so that bow heads into the sea
  - seat 2 and seat 4 stand on the iako tongues; lean over the canoe; grab the iako
  - seat 3 lifts the iako; seats 2 and 4 rock back to roll the canoe upright.
  - seat 5 catches the ama then sits on (or hangs onto) it to stabilize the canoe - take a moment to have everyone look for personal belongings in the water
  - 2 crew members at a time enter the canoe and bail like crazy - the remaining crew members continue to 'swim' the canoe towards the shore (while keeping the bow headed into the sea)
5. *Normally ordered* above, means not etched in stone. The orders given by the steerer must be direct and specific, to instill confidence. Exactly which seat does what is unimportant.
6. The steerer must keep track of each crew member at all times.
7. Resume paddling - continue with the paddling trip plan

### The Huli

(Ocean River Paddling Club)

Capsize/recovery of the 6-person outrigger canoe

---



To ensure a safe and efficient recovery from a huli or capsized in the six-person outrigger canoe, paddlers must be knowledgeable on the following steps.

The boat has capsized. Check that the people around you are O.K.

The captain should call out all the seat numbers to ensure all are well.

- Each seat number has a job to do:
- Seat 1 and 6 are to collect the paddles.
- Seat 2 and 5 are to go to the ama.
- Seat 3 and 4 go over the hull of the boat by stepping on the aikos then placing their feet on the mukus on the opposite side of the boat. They lean over the hull and grab on to the aikos.

When the team is ready seats 2 and 5 push the ama into the air; seats 3 and 4 pull the aikos up and over the hull; seats 1 and 6 either steady the boat in the waves or assist on the ama (depending on weather conditions) while holding onto the paddles.

Once the boat is upright, seats 3 and 4 stay with the ama pulling their bodies out of the water onto the aikos at the ama end; seats 2 and 5, and 1 and 6 get into the boat and start bailing right away.

Seats 3 and 4 get into the boat once it is more stable. Always bail and lean left.

Put on dry clothes and paddle to safety if required.

### **Huli**

Vernon Racing Canoe Club

In Hawaiian, the word "huli" means to turn over. If you huli your canoe:

First and foremost, count heads to make sure everyone is OK.

Seat 6 is in command and gives all commands.

Check for partners: 1 and 2; 3 and 4; 5 and 6. If anyone is missing, seat 6 will assign a paddler to take two lifejackets and search for the missing paddler.

Next turn the boat back over.

Position the boat sideways to the prevailing swell.

Seats 3 & 4 position themselves over the hull on the side opposite the ama to help pull the boat over (stand on the ends of the iakos)

Seat 1 collects the paddles swimming front to back.

Seats 2 & 5 position themselves at the ama, push down on the ama and then lift the ama to help turn the canoe over

Seat 6 controls the actions.

When you have turned the boat over,

seat 5 gets back in the boat to start bailing.

Everyone else should move to the ama side and keep the boat steady.

Trade off bailing duties until the boat is at least 75 percent dry.

During this time, 1 seat should be putting paddles back in the boat.

When the water is about ankle deep get back in the boat from the left (ama) side and begin paddling (don't worry about finding the "right" paddle. At this point only Seat 6 needs the correct paddle. For now, 1, 2, and 3 paddle, 6 steer, 4 & 5 KEEP BAILING. Note that if you need to switch paddles later, turn to your left (ama) side when passing paddles back and forth.

### **Huli**

Waikiki Yacht Club Canoe Team

In Hawaiian, the word "huli" means to turn over. If you huli your canoe:

First and foremost, count heads!

Then remember, DON'T PANIC. Your boat will float just at the surface for a little while at least.

Move your nose or tail into the swell, then:

Seats 1 & 6 position themselves over the hull on the side opposite the 'iako to help pull the boat over

Seat 5 collects the paddles

Seats 2 & 4 position themselves under the 'iako, then lift the 'iako to help turn the canoe over

Seat 3 positions in the middle of the canoe on the side opposite the 'iako to help pull the boat over

---

When you have turned the boat over, the smallest or lightest person gets in to start bailing.

Get back into the boat when your steersman tells you to.

### Huli Fix Procedures

Kent Island Outrigger Canoe Club

Sooner or Later, You Huli

ALWAYS BE READY TO SWIM. DO NOT CARRY ANYTHING IN THE BOAT THAT YOU ARE NOT READY TO LOSE TO THE WATER. This includes wallets, pagers, jewelry, watches, clothes, cell phones, etc). Make no mistake about it, at some point in time you will find yourself in the water!

1. First and foremost, do not panic. Find your paired seat.

Seat 1 and 2 find each other.

Seat 3 and 4 find each other.

Seat 5 and 6 find each other.

2. Collect paddles and hand them to Seat 1 or Seat 6. It's particularly important to do this as soon as possible in rough or windy conditions.

3. The steersman is in charge.

S/he will call for a headcount. It is imperative that the steersman account for everyone on the crew.

Each paddler calls out their seat number in sequential order beginning with seat 1.

Depending on conditions you may need to put your PFD on. If you want it on, put it on regardless of conditions!

4. The boat may need to be repositioned if there are large swells. Listen for directions.

5. Seat 1 collects the paddles, if possible.

6. Two people position themselves over the hull on the side opposite the 'iako to help pull the canoe over. The other two people are on the 'iako side to help lift the 'iako to turn the canoe over.



7. Once the canoe is righted, one person will get in and start bailing.

Get back in the boat when the steersman tells you to. Do not hang on the boat while it is being bailed.

.

.

# Coming Back

---

## Landing

### Landing the Canoe on the Beach

Kihei Canoe Club

1. Within a 1/4 mile of the Club (or other intended beach) - conduct a brief back paddling exercise, - all paddling on the left.
2. Instruct the stroker keep the bow headed into the sea.
3. Explain to the crew that it is a practice exercise is in preparation for going ashore.
4. It is critically important that the stroker and the steerer keep the canoe pointed into the waves, while approaching the beach, backwards.
5. Gain enough momentum and speed to keep the canoe running straight
6. ALTERNATIVE - instruct the stroker to turn 180 degrees in his seat, so he is facing the beach. From this position, the stroker can see well and 'steer' the canoe right onto the beach. The steerer remains in command.
7. The rest of the crew concentrates on back paddling - ALL ON THE LEFT
8. If the bow falls off badly during the approach - immediately paddle forward back out to sea and start the approach over again.
9. The heavier the wave conditions, the further out from the beach you line up, to start back paddling. Typically you have 6 second between waves - that's a short time.
10. Land one canoe at a time, to eliminate the risk of collision
11. Watch the waves and pick a small set to ride in on.
12. To judge the size of the waves in a set from off-shore, watch the beach to see how far up the foam goes.
13. Time is in your favor - don't rush it
14. When the wave you intend to use is say, 100 feet off the bow, order back paddling - keep talking to the crew, to control the pace - "back paddle" "back paddle" "back paddle"
15. Ride the wave towards the beach into shallow water - knee-deep water.
16. ALTERNATIVE for high surf - land the canoe by paddling straight in (bow first) [later, rotate canoe 180 degrees on land - away from the breaking waves]
17. Immediately order, "everybody out!" (leave all paddles in the canoe)

### CANOE ETIQUETTE

It is believed that canoes have a life to them. Each has a distinct and separate personality on the water. The canoe is part of the team, and carries all paddlers safely onto the water and home again. We expect all paddlers to treat the canoes with respect and never take them for granted or treat them discourteously.

Never sit or lean on a canoe except in the designated seat area once the canoe is in the water. Even sitting in the seat on land can cause the canoe to crack. When canoes are lifted, be sure the ama and 'iako are supported and off the ground. Canoes should not be dropped, but set down lightly.

Don't step over the body of the canoe. If you need to move to the other side, walk around the canoe. It is a gesture of courtesy to the canoe to do so.

---

## CANOE PARTS



### Respecting Your Outrigger

#### Hana Hoe Series

1. Respect every canoe as a family member. From the time a canoe is made and blessed, the canoe becomes an entity unto itself. Care for it as a loved one by maintaining it before setting out to sea and cleaning it after you return. Never sit on, or step over, a canoe (exceptions are sometimes made for dry-land training or demonstration purposes). If you must, support the hull along the kua`e/keel (the center line along the outside/bottom of the hull) in a way that will distribute the weight evenly to avoid placing too much stress at any one point. In Hawai`i, it is believed that to step over another is to cut their life shorter, therefore, the same applies to your canoe.

2. On land, the canoe always faces the ocean. This relates back to ancient Hawai`i when canoes were frequently used to repel attacks from other islands. "Stacking" is sometimes necessary to accommodate available space (placing the ama of a subsequent canoe on the `iako of a previous canoe).

3. Care should also be taken for the area surrounding the canoe. Pick up opala (rubbish) on and around your paena wa`a (canoe landing), halau wa`a (canoe house), or auha (canoe shed). Put things away that need to be stored without being asked.

Hoe aku i ka wa`a (do your share - [literally] move ahead the canoe)

4. Everyone helps when the canoe is being carried, covered, cleaned or cared for. This includes loading and unloading the canoes, covering or storing them, cleaning them and washing them down with fresh water (especially the lashings) when they are dirty or after practice, and checking all parts of the canoe before and after practice. This applies to every member of the club from the first time novice to the president. From ancient times, whenever there was a large undertaking, everyone would help by doing whatever they could. The strong would do the work, the old would offer encouragement and advice, and the young would bring the water and food, but everyone would participate.

A`ohe hana nui ka alu`ia. (No task is too big when done together).

5. Customarily, a prayer is always said before every launching no matter how long or short the voyage. The prayer needn't be long and perhaps not in Hawaiian, nor does it have to be religious in nature. Doing so helps center the crew mentally and spiritually (no religious reference).

6. On water, avoid standing, arguing and swearing in the canoe. Standing is rarely a good idea for stability and safety reasons anyway. Arguing and swearing only serves to upset the entire crew's efforts and create animosity instead of aloha. Avoid tracking dirt and sand into the outrigger when you climb aboard.

`Ike aku, `ike mai, kokua aku, kokua mai. Pela iho la ka nohana `ohana (Recognize others, be recognized, help others, be helped. Such is a family relationship).

7. Learn the particular duties that go along with the seat you sit in. Once you step into a canoe you are part of a team. Therefore every hoa wa`a (canoe mate) must work together by doing his share. The only way to know what is expected of each member is to have clearly defined assignments before hand.

Komo mai kau mapuna hoe (Dip your paddle in. Join in the effort.)

8. See to it that personal issues are put to rest quickly instead of letting them collect and fester in your mind. Remember: what happens on land, stays on land, what happens at sea, stays at sea. Show respect, enthusiasm and commitment to your hoa wa`a by arriving on time to practice (steersmen, coaches and other leaders should ALWAYS arrive early). -A leader is never on time, he is always early.

9. Take the time to study and learn the proper Hawaiian names and pronunciation of the things you use. On this issue, if you choose to use English (usually the case), or Tahitian, etc. that is entirely fine. But if you choose to use Hawaiian terminology, take care in its' pronunciation (and use). Many Hawaiian words have multiple meanings or have different meanings if pronounced incorrectly. Lest you be guilty of ""olelo ho`ohepa" (idiot talk).

### **Canoe Blessing**

The following was written by Iwalani Christian, priestess, in a message to member Ina Talalemotu prior to the canoe blessing ceremony held at the Na Po' e Hoe Lokahi Double Hull Race, hosted by Mountain Home Canoe Club May 10, 2003.

#### *CANOE BLESSING CEREMONY PROTOCOL*

- \* A Blessing is a consecration to invoke divine care for those things and/or persons who fulfill our lives through prayer and ceremony. A means of honoring, giving thanks and well wishes and positive energy and to dissipate any ill wishes and negative energy. To give approval and encouragement.
- \* Ceremony is a formal act or series of acts as prescribed by ritual, protocol or convention.
- \* Protocol is a code prescribing strict adherence to correct etiquette and precedence.
- \* Ritual is the established form for a ceremony. A ritual observance is a system of rites, a ceremonial act or action.

#### *SOME GENERAL NOTES FOR A CANOE BLESSING*

Wa'a to be blessed are to be on the beach with the manu ihu (nose) towards the water just a bit over the very edge of the water. Beach should be cleared and free of any other paraphernalia. Everyone on the beach during ceremony is considered a witness/participant and will form a semi circle around the canoe. (That's everyone on the beach). Will need to facilitate 6 paddlers (they should all be kane (men), sorry wahine (women), but tradition, you know.) to paddle the wa'a out with the puolo (offering). The canoe is to go straight out, then a turn towards the East (left turn), the offering is dropped, then back to the ceremony site bringing the right side of the canoe parallel with the shore. Paddlers get out of the canoe and hold it in place till ceremony is ended. Then the wa'a is beached once again with the nose facing out. I suggest the honoree take the kapena position (steersman) and a young member in noho 'ekahi (seat one or stoker) with a kupuna (elder) in the center. This will symbolize the generations, full circle. Bring your paddles to Blessing Area on the beach; leave your cases and paddle covers and other ukana (baggage, coats, shoes, purses, etc.) locked in your cars. Carry your paddle with the blade up, not down (so the mana does not flow out and absorbed by the sand). There is no unnecessary talking during the ceremony.

So here's the protocol (Order of things):

Clearing and Purification (so the ceremony may begin) Pa'akai (sea salt) will be passed to all witnesses/participants while the purification/clearing chant is done. Take a pinch of salt and put it under your tongue. Salt is a symbol of purification and prepares the witness to be pure in thoughts and feelings for the ceremony.

Permission Here a prayer is offered to ask the tree for forgiveness in the taking of its life and celebrating the dawning of its life as a wa'a (canoe). A lei is placed on the manu ihu of the canoe during the prayer. A prayer to ask the ancestors presence is then done.

Blessing The canoe is blessed with a blessing and honor chant. Noho 'Ekahi carries the offering. After the blessing chant is completed and the manu ihu is consecrated (with the pouring of 'awa and salt and water over the nose), the paddlers may recite a prayer, chant, or do a haka.

Offering The paddlers get into the canoe and paddle out to make the offering. Paddle straight out a ways. Make a left turn. During the turn, the offering is dropped into the water. Canoe then heads straight back to shore, nose first. The paddlers get out of the canoe and stand beside it for the final prayer.

Closing the Ceremony The paddlers get out of the canoe and stand beside it for the final prayer. The paddlers will push the canoe back up on the beach with the nose facing out. The ceremony is ended

---

## **Rigging**

### **Rigging**

Kent Island Outrigger Canoe Club

Sennet, hand twisted from natural fibers, was the original cordage used to lash the 'iako to the ama and the main hull. While many lashing styles were used, the primary purpose was to ensure the canoe's safety. If lashings broke, they would not unravel because of the cord's interlacing and cinching.

Rigging is what keeps the main hull, the 'iako, and the ama together. An important part of paddling is to learn the culture. This includes learning traditional Polynesian lashing techniques. The KIOCC Force Fives and Duke are each primarily lashed using these methods. Secondary, or temporary, lashing can be made with modern snap-lashes. However, each paddler is expected to not only learn but to assist in rigging the boats. A video is available for team member use.

---



*'iako to wae and mo'o showing other important tools - tape measure, level, and line wax*



*'iako to ama showing a clean and strong connection in the final wrapping and knot*

Photos courtesy Outrigger Rio Clube (Brazil) - <http://www.outrigger.com.br/>

### **Rigging**

Vernon Racing Canoe Club

All paddlers should know how to rig a boat. If you get to practice and find your boat has loose rigging, you should take the initiative to re-rig the loose section.

Among some clubs there is only "one way" to properly rig a canoe. However, in looking over the rigging on the boats at major races like the Queen Liliuokalani race in Kona or the Molokai Hoe, it's clear that the folks from Maui rig differently than the folks from Oahu, and the rigs from New Zealand crews are radically different from the Hawaii crews. Even the North Shore Oahu clubs rig differently from the South Shore clubs.

So, pragmatically, an acceptable rig on a canoe is one that holds the parts together in "moderate" ocean chop. Or put another way, "If it doesn't fall off, it's fine."

In our club, Nancy Schneider's way is best.

That's not to say one technique isn't better than another. Those paddlers and coaches who have years of experience have developed lacing systems that can stand up to very rough ocean conditions.

When boats are being rigged, come and watch and learn. Then the next time, try it yourself.

# Crew Stuff

---

## Recreational Paddling Addendum

### Kihei Canoe Club

1. The ama should be rigged high to cause the canoe to lean towards the ama. This is achieved by the insertion of blocks under the iako.
  2. An unusually heavy crew causes the canoe to sit lower in the water and causes the ama to sit higher. The crew should be advised to take extra care in these circumstances to lean to the ama side, to minimize the risk of a huli.
  3. The heaviest crew members should be seated in seats 3 and 4; the next heaviest in seats 2 and 5; and, the lightest crew members should be seated in seats 1 and 6. This keeps the canoe (bow and stern) responsive to larger waves and minimizes the taking on of water particularly when the bow does not respond quickly.
  4. The trip plan should travel in such a direction that the return leg presents the wind at the paddlers' backs.
  5. Never ever paddle the canoe in shallow water near the 'break' except for departing or returning to the beach - a time when canoe is kept perpendicular to the beach.
  6. The steerer is always in command - his crew should never take instructions from anyone else - on shore, in another boat, etc. If a Beach Captain must give instructions - they are to be assessed and dealt with by the steerer, only.
  7. Never call for all paddlers to paddle on the right.
  8. Never intentionally cause the canoe to huli - it is not worth the risk of injury that can occur.
  9. Whales must not be approached closer than 6 canoe lengths (100 yards). Should a whale swim closer to the canoe than 100 yards, all paddling is to cease until the whale moves beyond 100 yards.
  10. Never go out (or get caught out) during the hours of darkness.
- 

## Tips

### Vernon Racing Canoe Club

#### Tips for Veterans

Paddling with a beginner may renew your enthusiasm

**ENCOURAGE:** Likely one dozen people that you know, would like to give paddling a try but have no idea how to begin. They will not likely approach you, for fear of slowing you down. Invite them for a paddle - do a shorter, slower workout.

**HOLD BACK:** Beginners may need to go slowly at first. Building a base of fitness requires 4-8 weeks. Many beginners increase distance or speed too quickly or paddle too many days/week, resulting in aches, pains, loss of motivation, and longer recoveries.

Don't push the stroke rate with beginners. Technique must come first.

**TAKE BREAKS:** Incorporate breaks into your paddle with a novice.

#### Tips for Beginners

**JUST ASK:** Don't feel intimidated or uncomfortable asking questions of veterans. We were all beginners. Veterans love to answer questions about paddling and once started, you may find they are sometimes hard to

---

## Possible Injuries

### Hong Kong Paddle Club

Injury can result from factors other than a lack of sufficient warm-up, however, and it is important to be aware of what these may be and what to do if an injury is sustained.

Improper technique, for instance, is the usual cause of injury by unduly stressing joints, tendons and muscles. Sudden damage occurs when a tendon, cartilage or a muscle is torn, but more often injury in outrigger canoeing is the result of improper technique due to small amounts of stress adding up over time to adversely affect the body. Other injuries result from simply over use of a joint, muscle or tendon.

#### Shoulders

Shoulders are the usual areas subject to injury caused by excessive movement which goes beyond the natural range of motion (if there ever is such a thing in this sport). For example, there is a tendency to over reach and apply power to the stroke without first stabilizing the shoulder with the adductor muscles around the shoulder

---

blade (scapula), particularly when a paddler gets tired at the end of a session. Or on the recovery, if the upper shoulder 'hunches up' too high rather than staying 'locked down' by the scapula abductors, it can cause an impingement problem and pain.

Most problems associated with shoulders, in fact, are usually related to rotator cuff and subacromial bursa impingement. This can happen either in the boat or most commonly in the weight room. Bench Press and Military Presses are the worse offenders particularly when the shoulder muscles 'bunch' up at the top end of a repetition.

#### **Wrists and Forearms**

Pain in both upper and lower wrists usually results from cocking the wrist one direction or another during the power phase or recovery of the stroke. This practice can add tremendous strain on forearm flexors causing inflammation of tendons particularly close to the elbow not unlike tennis elbow. Tunnel carpal syndrome can also develop causing a numbness to fingers.

The best way to alleviate these problems is to develop a 'softer' grip on the paddle with your lower hand and to minimize wrist movement during the stroke.

#### **Lower Back**

Herniated disks or strained muscles can result from improper technique of inadequate stretching, particularly as we grow older. The principle means to mitigate lower back pain or injury is to develop a strict exercise regime that target strengthening back muscles and provides for flexibility.

More often than not, lower back pain results from a strength imbalance where for example the abdominals may be stronger than the erectors; or perhaps where the lower abdominals are not as developed as the upper abdominal muscles. Other stabilizing muscles should not be overlooked in training such as the Gluteus maximus, hamstrings and Quadriceps. Weakness or lack of flexibility here can result in back pain as well. But take care! Doing sit-ups while holding weights is a sure way to invite injury.

#### **Knees**

Strangely enough paddlers often have knee problems associated with over-development of the Quadriceps or off centre loading. The intense isometric load on the quads when paddling combined with dryland training such as squats, rowing machines or running can create an imbalance between the Quads and the Hamstrings at the back of the thigh. This can result in excessive wear on the cartilage as the kneecap is pulled upward due to a weak resistance from the opposite direction. Hamstring curls to strengthen the back of the leg will alleviate the problem in a short time.

#### **Chest**

Intense deep pain in the lungs sometime occurs when your not getting enough oxygen and can be expected if your pushing the limits of performance, however, it can also be a symptom underlying heart disease.

---

## **Common Injuries**

Hong Kong Paddle Club

The following is a description of common injuries to paddling and the associated care for rehabilitation:

#### **Tendinitis**

Tendinitis is the inflammation of tendons which connect muscles to bone, and is usually the result of overuse of an extremity. Generalized nagging pain is experienced rather than pain in a specific location and is often associated with light swelling. Pain is most intense after exercise.

The problem with this injury is that continued use of the extremity will aggravate the injury further, therefore total rest is the key. Starting back into training too soon will only prolong healing. Vigilant rest, ice and sometimes anti-inflammatories or aspirin will help the recovery.

#### **Strains**

Strains result from a stretched or torn muscle or tendon. Generalized pain, mild swelling and occasional bruising are the symptoms. Given the complex nature of shoulders, the actual location of pain may in fact not be the source of the problem. Rest, ice, compression and elevation are the best forms of treatment followed by easy exercise within a week or two. It is important to work such an injury back in slowly rather than leaving it alone totally to avoid excess build up of scar tissue and potential restriction of movement.

#### **Sprains**

The infamous 'POP' sometimes heard at the moment of an injury is the rupture of a ligament which connects one bone to another, resulting in a sprain. Sprains are rare in dragonboating due to a restricted range of motion, but have very similar symptoms to a sprain, ie. generalized pain, mild swelling and possible bruising.

---



### **Bursitis**

There is a fluid-filled sac in the shoulder which separates muscles and tendons from bone that can become inflamed causing acute pain, or can become completely deflated causing chronic pain. Pain will be point specific centred around the joint and will often flare up after activity. Acute bursitis can be treated with rest, ice and anti-inflammatories, while chronic bursitis is much more severe and may require more drastic treatment such as fluid injections etc. Rest is advised.

### **Shoulder Dislocation**

Rare, but when it happens you'll know it! Paddlers have been known to pop their shoulder back into place and keep on paddling. This is not advisable. Light traction is used to 'relocate' the shoulder joint and then the arm should be put in a sling. With rest paddling can resume in a short time. Chronic dislocation may need surgery to correct.

### **In summary some basic rules should be applied to avoid injury**

keep movements *strict* either in the boat or in dryland training by constantly evaluating technique and adhering to prescribed movement patterns;

never work through pain in the joints, rather ease off or rest and stretch until the pain subsides and it is comfortable to paddle;

try to develop muscles opposite of those use to paddle in order to balance strength and ability;

never overload your body beyond its ability;

build up 'strength' gradually, in controlled phases to avoid over-reaching;

restrict 'strength' training to pre-race or earlier stages of a training programme to provide a solid 'base' and minimize risk of injury effecting race preparation;

be disciplined in 'stretching down' after practice or warming up before;

seek sports massage or manipulation therapy as a preventative measure; cross-train to develop muscles for a broader range of physical activity.

### **Staph Infection**

Waikiki Yacht Club Canoe Team

At most times, the Yacht Harbor at Magic Island has good water. However, after a heavy rain the runoff from town literally flushes the Ala Wai Canal into the yacht basin and our site is polluted. Also, on days when wind or sea conditions make it unsafe to practice on the ocean, your coach may decide to work out on the Ala Wai Canal. At these times you must be careful of staph infection.

According to Dr. Ben Tamura, head of medicine at Kaiser Honolulu and a long-time paddler and kayak enthusiast, staph begins as one or more tiny red sores or pimples -- especially at the pant or bra line, although they can appear anywhere.

Some paddlers will pass this off as a friction rash from rubbing against the seat or side of the canoe. It is really the staph bacteria infecting the pores of the skin.

To prevent the infection from spreading deeper into the layers of skin, or even into the muscle, it is important to wash immediately after your practice and changing into loose fitting clothing. If a staph infection does start, treat it with over-the-counter bacterial creams.

---